



# ODYSSEY

31THRG10  
OG07600  
00X31-THR-G100

[owners.honda.com](http://owners.honda.com) (U.S.)  
[myhonda.ca](http://myhonda.ca) (Canada)  
2019 Honda ODYSSEY Owner's Guide  
© 2018 Honda Motor Co., Ltd. — All Rights Reserved

Printed in U.S.A.



2019  
OWNER'S GUIDE

# DISCLOSURES

## Devices That Emit Radio Waves

The following products and systems, if on your vehicle, emit radio waves when in operation:

- HondaLink®\*1
- Audio System
- Blind Spot Information System\*1
- Bluetooth® Audio
- Bluetooth® HandsFreeLink®
- Collision Mitigation Braking System™ (CMBS™)\*1
- Homelink® Universal Transceiver\*1
- Immobilizer System
- Remote Engine Start System with Vehicle Feedback\*1
- Remote Transmitter
- Smart Entry System\*1
- Tire Pressure Monitoring System (TPMS)
- Wireless charger\*1
- Parking Sensor System\*1
- Rear Entertainment System Remote Control\*1

Each of the above complies with the appropriate requirements or the required standards of the FCC (Federal Communications Commission) and Industry Canada, described below:

*As required by the FCC:*

*This device complies with Part 15 of the FCC rules. Operation is subject to the following two conditions: (1) This device may not cause harmful interference, and (2) this device must accept any interference received, including interference that may cause undesired operation.*

*Changes or modifications not expressly approved by the party responsible for compliance could void the user's authority to operate the equipment.*

*As required by Industry Canada:*

*This device complies with Industry Canada licence-exempt RSS standard(s). Operation is subject to the following two conditions: (1) this device may not cause interference, and (2) this device must accept any interference, including interference that may cause undesired operation of the device.*

## Disclaimer

The information and data contained herein are believed to be accurate and reliable. American Honda Motor Co., Inc. makes no warranty of any kind and accepts no responsibility for the results obtained through application of this information.

*\*1 - If equipped*

## Privacy Notice

This vehicle may share location and usage information. To manage this setting, visit [www.hondalink.com/vehicle-data-choices](http://www.hondalink.com/vehicle-data-choices).

## Event Data Recorders

**This vehicle is equipped with an event data recorder (EDR).** The main purpose of an EDR is to record, in certain crash or near crash-like situations, such as an airbag deployment or hitting a road obstacle, data that will assist in understanding how a vehicle's systems performed. **The EDR is designed to record data related to vehicle dynamics and safety systems for a short period of time, typically 30 seconds or less. The EDR in this vehicle is designed to record such data as:**

- **How various systems in your vehicle were operating;**
- **Whether or not the driver and passenger safety belts were buckled/fastened;**
- **How far (if at all) the driver was depressing the accelerator and/or brake pedal; and,**
- **How fast the vehicle was traveling.**

These data can help provide a better understanding of the circumstances in which crashes and injuries occur. NOTE: EDR data are recorded by your vehicle only if a non-trivial crash situation occurs; no data are recorded by the EDR under normal driving conditions and no personal data (e.g., name, gender, age, and crash location) are recorded. However, other parties, such as law enforcement, could combine the EDR data with the type of personally identifying data routinely acquired during a crash investigation.

To read data recorded by an EDR, special equipment is required, and access to the vehicle or the EDR is needed. In addition to the vehicle manufacturer, other parties such as law enforcement that have the special equipment can read the information if they have access to the vehicle or the EDR.

The data belong to the vehicle owner and may not be accessed by anyone else except as legally required or with the permission of the vehicle owner.

## Service Diagnostic Recorders

This vehicle is equipped with service-related devices that record information about powertrain performance. The data can be used to verify emissions law requirements and/or help technicians diagnose and solve service problems. It may also be combined with data from other sources for research purposes, but it remains confidential. Some diagnostic and maintenance information is uploaded to Honda upon vehicle start up.

# INTRODUCTION

This Owner's Guide is intended to help you quickly get acquainted with your **2019 ODYSSEY**. It provides basic information and instructions on technology and convenience features, as well as emergency procedures and how to get assistance.

This guide is for vehicles sold in the United States and Canada. It covers all models, so you may find descriptions of features and equipment that are not in your vehicle. Images throughout this guide are from U.S. vehicles and represent features and equipment that are available on some, but not all, models.

This guide is not intended to be a substitute for the Owner's Manual. Visit [owners.honda.com](http://owners.honda.com) (U.S.) or [myhonda.ca](http://myhonda.ca) (Canada) to view the most current Owner's Manual, Navigation Manual, Vehicle Warranty, and the tire manufactures' warranties.

**If you are the first registered owner of your vehicle, you may request a complimentary printed copy of the Owner's Manual, Navigation Manual, or Vehicle Warranty within the first six months of vehicle purchase.** To request a copy, visit [owners.honda.com](http://owners.honda.com) and create or log in to your account. In Canada, please request a copy from your Honda dealer.

American Honda Motor Company strives to be proactive in protecting our environment and natural resources. By using electronic delivery for a considerable portion of the information typically found in a vehicle Owner's Manual, we are further reducing our impact on the environment.

## Honda Automobile Customer Service

Your authorized Honda dealer should be able to answer any questions you have about your vehicle. However, if you are dissatisfied with the information you receive, you can call Honda Automobile Customer Service.

**Call (800) 999-1009 (U.S.) or (888) 946-6329 (Canada)**

## Honda Roadside Assistance

24-hour emergency road service is available to you in the United States and Canada throughout your 3-year/36,000-mile warranty term. Services include jump starting, flat tire and lockout assistance, towing, and more (limitations apply).

**Call (866) 864-5211 (U.S.) or (800) 465-7587 (Canada)**

# TABLE OF CONTENTS

<b>VISUAL INDEX</b> .....	1	Climate Control System.....	52
Steering Wheel and Nearby Controls.....	1	Front Seat Heaters and Ventilation- If equipped.....	53
Dashboard and Nearby Controls.....	2	Customized Features.....	54
<b>SAFETY INFORMATION</b> .....	3	Setting the Clock.....	55
Important Safety Information.....	3	HondaVAC™ - If equipped.....	55
Seat Belts.....	4	<b>AUDIO AND CONNECTIVITY</b> .....	56
Airbags.....	7	Basic Audio Operation.....	56
Child Safety.....	13	Color Audio System.....	58
Safety Label Locations.....	21	Display Audio System.....	59
Reporting Safety Defects.....	22	HondaLink® .....	59
<b>INSTRUMENT PANEL</b> .....	23	HondaLink® Assist- If equipped....	60
Malfunction Indicators.....	23	Apple CarPlay™ .....	60
Condition Indicators.....	24	Android Auto™ .....	62
On/Off Indicators.....	25	Wi-Fi Connection.....	63
Driver Information Interface.....	27	System Updates.....	63
<b>VEHICLE CONTROLS</b> .....	28	FM/AM Radio.....	65
Using the Remote Transmitter.....	28	SiriusXM - If equipped.....	66
Smart Entry System- If equipped....	29	iPod®.....	66
Door Operation.....	30	USB Flash Drive.....	68
Tailgate Operation.....	33	Bluetooth® Audio.....	69
Power Window Operation.....	35	Compact Disc (CD)- If equipped.....	71
Power Moonroof Operation- If equipped.....	36	<b>BLUETOOTH® HANDSFREELINK®</b> .....	73
Interior and Exterior Lights.....	37	Basic HFL Operation.....	73
One-Touch Turn Signal.....	39	Pairing a Phone.....	74
Auto High Beam System- If equipped.....	39	Making a Call.....	76
Wiper Operation.....	41	Siri™ Eyes Free.....	79
Adjusting the Seats.....	42	<b>NAVIGATION</b> .....	80
Driving Position Memory System- If equipped.....	43	Basic Navigation Operation.....	80
Adjusting the Head Restraints.....	44	Entering Your Destination.....	81
Adjusting the Rear Seats.....	45	Routing.....	84
Floor Mats.....	49	<b>DRIVING</b> .....	85
Adjusting the Steering Wheel.....	49	Before Driving.....	85
Adjusting the Mirrors.....	49	Maximum Load Limit.....	86
Homelink® Universal Transceiver- If equipped.....	51	Towing a Trailer.....	88
		Towing Behind A Motorhome.....	90
		Starting to Drive.....	90
		Shifting.....	91

Auto Idle Stop- If equipped..... 93  
 Braking..... 94  
 Intelligent Traction Management System..... 95  
 Vehicle Stability Assist® (VSA®) System..... 96  
 Honda Sensing® ..... 96  
 Cruise Control- If equipped..... 97  
 Adaptive Cruise Control (ACC) ..... 99  
 Lane Keeping Assist System (LKAS)- If equipped..... 102  
 Road Departure Mitigation (RDM)- If equipped..... 104  
 Collision Mitigation Braking System™ (CMBS™)- If equipped..... 105  
 Blind Spot Information System- If equipped..... 107  
 LaneWatch™ - If equipped..... 108  
 Parking Sensor System- If equipped..... 109  
 Cross Traffic Monitor - If equipped..... 110  
 Multi-View Rear Camera..... 111  
 Improving Fuel Economy and Reducing CO<sub>2</sub> Emissions..... 112  
 Refueling..... 112

**HANDLING THE UNEXPECTED..... 114**  
 Smart Entry System Battery Strength..... 114  
 Jump Starting..... 114  
 Overheating..... 115  
 Emergency Engine Stop..... 116  
 Emergency Towing..... 117  
 Tire Pressure Monitoring System (TPMS)..... 117

Changing a Flat Tire..... 118  
 Fuse Locations..... 123

**MAINTENANCE..... 126**  
 Safety Precautions..... 126  
 Maintenance Minder™..... 127  
 Under the Hood..... 129  
 Engine Oil..... 131  
 Engine Coolant..... 133  
 Checking the Battery..... 134  
 Window Washer Fluid..... 134  
 Brake Fluid..... 134  
 Changing Wiper Blades..... 135  
 Tire Information..... 136  
 Tire Labeling..... 139  
 DOT Tire Quality Grading..... 140  
 Testing of Readiness Codes..... 142

**SPECIFICATIONS..... 143**

**CUSTOMER INFORMATION..... 144**  
 Frequently Asked Questions/ Troubleshooting..... 144  
 Contact Us..... 145  
 Honda Roadside Assistance..... 145  
 Warranty Coverages..... 146  
 EPA Contact Information..... 146

**VOICE COMMAND INDEX..... 147**  
 Voice Portal Commands..... 147  
 Phone Commands..... 147  
 Audio Commands- If equipped..... 147  
 Navigation Commands- Models with navigation only..... 147

**INDEX..... 148**

# VISUAL INDEX

Quickly locate items in the vehicle's interior.

## Steering Wheel and Nearby Controls

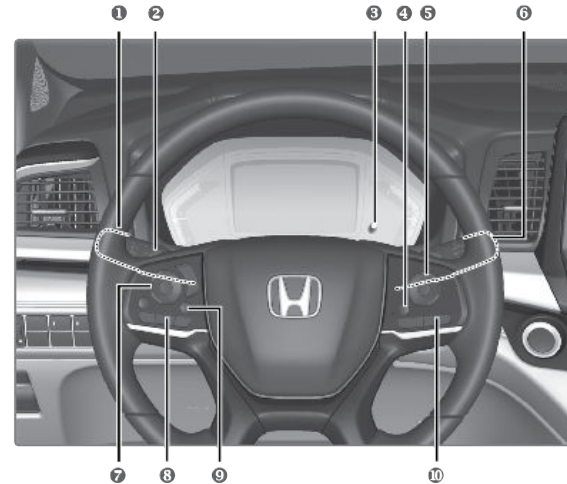

- 1 Headlights/Turn Signals  
Fog Lights\*1  
LaneWatch™\*1
- 2 Paddle Shifters
- 3 Brightness Control
- 4 Heated Steering Wheel Button\*1
- 5 Cruise Control\*1/Adaptive Cruise Control (ACC)\*1/Interval Button\*1
- 6 Wipers/Washers
- 7 Audio Remote Control Buttons
- 8 Bluetooth® HandsFreeLink® Buttons
- 9 Home Button
- 10 Lane Keeping Assist System (LKAS) Button\*1

\*1 - If equipped

**Dashboard and Nearby Controls**

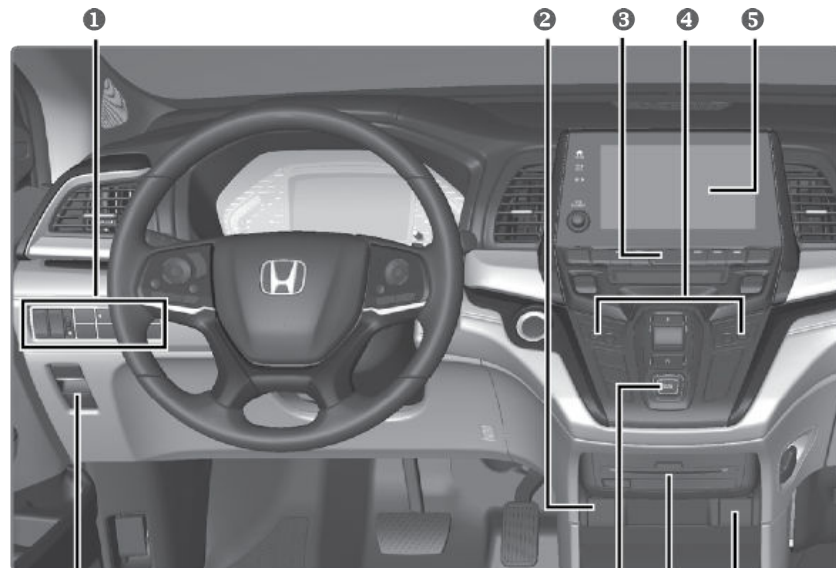

- ❶ Vehicle Stability Assist® (VSA®) System OFF Button
- Collision Mitigation Braking System™ (CMBS™) OFF Button\*<sup>1</sup>
- Road Departure Mitigation (RDM) Button\*<sup>1</sup>
- Power Sliding Door Switch\*<sup>1</sup>
- Power Tailgate Switch\*<sup>1</sup>
- Parking Sensor System Switch\*<sup>1</sup>
- Heated Windshield Button\*<sup>1</sup>

- ❷ Accessory Power Socket
- ❸ Climate Control System
- ❹ Seat Heater and Ventilation Switches\*<sup>1</sup>
- ❺ Audio System
- Navigation System\*<sup>1</sup>
- ❻ Electric Parking Brake Switch
- Automatic Brake Hold Button
- ❼ Shift Button
- ❽ Rear Entertainment System\*<sup>1</sup>
- ❾ AC Power Outlet\*<sup>1</sup>

\*1 - If equipped

**SAFETY INFORMATION**

Your safety--and the safety of others--is very important and operating this vehicle safely is an important responsibility. While we strive to help you make informed decisions about safety, it is not practical or possible to warn you about all the hazards associated with operating or maintaining your vehicle. Therefore, you must use your own good judgement.

**Important Safety Information**

This guide explains many of your vehicle's safety features and how to use them. Please read this information carefully. Following the instructions below will also help to keep you and your passengers safe.

■ **Important Safety Precautions**

- Always wear your seat belt.
- Secure all children in the proper restraint system.
- Be aware of airbag hazards.
- Don't drink and drive.
- Pay appropriate attention to the task of driving safely.
- Control your speed.
- Keep your vehicle in safe condition.

Engaging in cell phone conversation or other activities that keep you from paying close attention to the road, other vehicles, and pedestrians could lead to a crash. Remember, situations can change quickly, and only you can decide when it is safe to divert some attention away from driving.

■ **Safety Messages**

When you see the following messages throughout this guide, pay close attention.

**⚠ DANGER** You WILL be KILLED or SERIOUSLY HURT if you don't follow instructions.

**⚠ WARNING** You CAN be KILLED or SERIOUSLY HURT if you don't follow instructions.

**⚠ CAUTION** You CAN be HURT if you don't follow instructions.

**NOTICE** This information is intended to help you avoid damage to your vehicle, other property, or the environment.

### ■ Carbon Monoxide Gas

The engine exhaust from this vehicle contains carbon monoxide, a colorless, odorless, and highly toxic gas. As long as you properly maintain your vehicle and follow the instructions set forth below, you will not accumulate dangerous levels of carbon monoxide gas in the vehicle interior.

Have the exhaust system inspected for leaks whenever:

- The exhaust system is making an unusual noise.
- The exhaust system may have been damaged.
- The vehicle is raised for an oil change.

When you operate a vehicle with the trunk open, airflow can pull exhaust gas into the interior and create a hazardous condition. If you must drive with the trunk open, open all the windows and set the climate control system as shown below:

1. Select the fresh air mode.
2. Select the  mode.
3. Set the fan speed to high.
4. Set the temperature control to a comfortable setting.

Adjust the climate control system in the same manner if you sit in your parked vehicle with the engine running.

#### WARNING

Carbon monoxide gas is toxic. Breathing it can cause unconsciousness and even kill you. Avoid any enclosed areas or activities that expose you to carbon monoxide.

An enclosed area such as a garage can quickly fill up with carbon monoxide gas. Do not run the engine with the garage door closed. Even when the garage door is open, drive out of the garage immediately after starting the engine.

### Seat Belts

A seat belt is your best protection in all types of collisions. Airbags are designed to supplement seat belts, not replace them. So even though your vehicle is equipped with airbags, make sure you and your passengers always wear your seat belts and wear them properly.

#### ■ Lap/Shoulder Seat Belts

All seven or eight seating positions are equipped with lap/shoulder seat belts with emergency locking retractors. In normal driving, the retractor lets you move freely while keeping some tension on the belt. During a collision

or sudden stop, the retractor locks to restrain your body. The rear seat belts also have a lockable retractor for use with child seats.

#### ■ Proper Use of Seat Belts

Follow these guidelines for proper use:

- All occupants should sit upright, well back in the seat, and remain in the position for the duration of the trip. Slouching and leaning reduces the effectiveness of the belt and can increase the chance of serious injury in a crash.
- Never place the shoulder part of a lap/shoulder seat belt under your arm or behind your back. This could cause very serious injuries in a crash.
- Two people should never use the same seat belt. If they do, they could be very seriously injured in a crash.
- Do not put any accessories on the seat belts. Devices intended to improve comfort or reposition the shoulder part of a seat belt can reduce the protective capability and increase the chance of serious injury in a crash.
- No one should sit in a seat with an inoperative seat belt or one that does not appear to be working correctly. Using a seat belt that is not working properly may not protect the occupant in a crash. Have a dealer check the belt as soon as possible.

#### WARNING

Not wearing a seat belt properly increases the chance of a serious injury or death in a crash, even though your vehicle has airbags.

Be sure you and your passengers always wear seat belts and wear them properly.

#### ■ Seat Belt Inspection

Regularly check the condition of your seat belts as follows:

- Pull each belt out fully and look for frays, cuts, burns, and wear.
- Check that the latch plates and buckles work smoothly and the belts retract easily. If a belt does not retract easily, cleaning the belt may correct the problem. Only use mild soap and warm water. Do not use bleach or cleaning solvents. Make sure the belt is completely dry before allowing it to retract.

Any belt that is not in good condition or working properly will not provide proper protection and should be replaced as soon as possible.

A belt that has been worn during a crash may not provide the same level of protection in a subsequent crash. Have your seat belts inspected by a dealer after any collision.

### ⚠ WARNING

Not checking or maintaining seat belts can result in serious injury or death if the seat belts do not work properly when needed.

Check your seat belts regularly and have any problem corrected as soon as possible.

#### ■ Fastening a Seat Belt

Adjust your seat to the proper position and then follow the steps below:

1. Pull the seat belt out slowly.
2. Insert the latch plate into the buckle, then tug on the belt to make sure the buckle is secure. Make sure that the belt is not twisted or caught on anything.
3. Position the lap part of the belt as low as possible across your hips, then pull up on the shoulder part of the belt so the lap part fits snugly. This lets your strong pelvic bones take the force of a crash and reduces the chance of internal injuries.
4. If necessary, pull up on the belt again to remove any slack, then make sure that the belt rests across the center of your chest and over your shoulder. This spreads the forces of a crash over the strongest bones in your upper body.

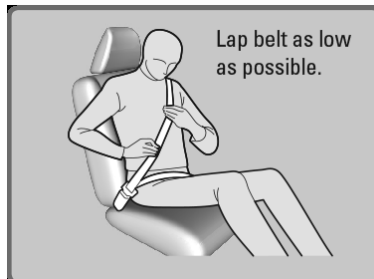
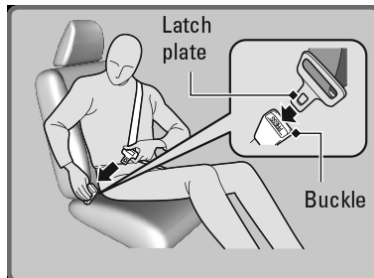

To release the belt, push the red PRESS button then guide the belt by hand until it has retracted completely.

### ⚠ WARNING

Improperly positioning the seat belt can cause serious injury or death in a crash.

Make sure all seat belts are properly positioned before driving.

#### ■ Adjusting the Shoulder Anchor

The front seats have adjustable shoulder anchors to accommodate taller and shorter occupants.

1. Move the anchor up and down while pulling the release outward.
2. Position the anchor so that the belt rests across the center of your chest and over your shoulder.

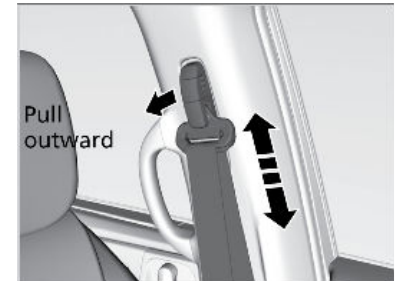

#### Airbags

Your vehicle is equipped with several types of airbags: front airbags, front knee airbags, side airbags, and side curtain airbags.

#### ■ Front Airbags (SRS)

The front SRS airbags inflate in a moderate-to-severe frontal collision to help protect the head and chest of the driver and/or front passenger. They are housed in the center of the steering wheel for the driver and in the dashboard for the front passenger. Both airbags are marked **SRS AIRBAG**. SRS (Supplemental Restraint System) indicates that the airbags are designed to supplement seat belts, not replace them. Seat belts are the occupant's primary restraint system.

#### Front Knee Airbags

The front knee SRS airbags inflate in a moderate-to-severe front collision to help keep the driver and/or front passenger in the proper position and to help maximize the benefit provided by the vehicle's other safety features.

#### ■ Advanced Airbags

The front airbags have advanced features to help reduce the likelihood of airbag related injuries to smaller occupants.

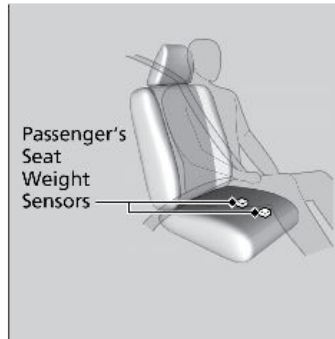
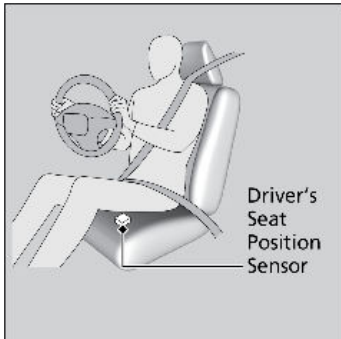

The driver's advanced front airbag system includes a seat position sensor. Based on information from this sensor and the severity of the impact, the advanced airbag system determines the optimal deployment of the driver's airbag.

The front passenger's advanced airbag system has weight sensors.

We advise against allowing a child age 12 or under to ride in the front passenger's seat. However, **if you do allow a child age 12 or under to ride in the front passenger's seat**, note that the system will automatically turn off the front passenger's airbag if the sensor's detect that the child is approximately 65 lbs (29 kg) or less.

For the advanced airbags to work properly:

- Do not spill any liquid on or under the seats.
- Do not put any object under the passenger's seat.
- Make sure any objects are positioned properly on the floor. Improperly positioned objects can interfere with the advanced airbag sensors.
- All occupants should sit upright and wear their seat belts properly.
- Do not cover the passenger's side dashboard with a cloth, towel, cover, etc.

#### ■ Side Airbags

The side airbags help protect the upper torso and pelvis of the driver or a front passenger during a moderate-to-severe side impact. They are housed in the outside edge of the driver's and front passenger's seat-backs. Both are marked **SIDE AIRBAG**.

#### ■ Side Curtain Airbags

Side curtain airbags help protect the heads of the driver and passengers in outer seating positions during a moderate-to-severe side impact. The side curtain airbags equipped in this vehicle are also designed to help reduce

the likelihood of partial and complete ejection of vehicle occupants through side windows in crashes, particularly rollover crashes.

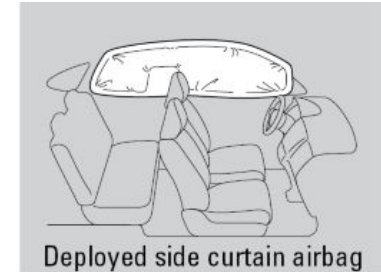
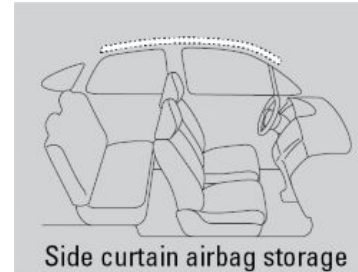

The side curtain airbags are located in the ceiling above the side windows on both sides of the vehicle.

The side curtain airbags are designed to deploy in a rollover or moderate-to-severe side impact. If the SRS control unit senses that your vehicle is about to roll over, it immediately deploys both side curtain airbags and activates both front seat belt tensioners. If the impact is on the passenger's side, the passenger's side curtain airbag will inflate even if there are no occupants on that side of the vehicle.

To get the best protection from the side curtain airbags, occupants should wear their seat belts properly and sit upright and well back in their seats.

Do not attach any objects to the side windows or roof pillars, as they can interfere with the proper operation of the side curtain airbags.

#### When side curtain airbags deploy in a frontal collision

One or both side curtain airbags may inflate in a moderate-to-severe angled frontal collision.

#### ■ Important Facts About Your Airbags

Always wear your seat belt properly, sit upright, and as far back from the steering wheel as possible while allowing full control of the vehicle. A front passenger should move their seat as far back from the dashboard as possible.

**Do not place hard or sharp objects between yourself and a front airbag.** Carrying hard or sharp objects on your lap, or driving with a pipe or other sharp object in your mouth, can result in injuries if your front airbag inflates.

**Do not attach or place objects on the front airbag covers.** Objects on the covers marked **SRS AIRBAG** could interfere with the proper operation of the airbags or be propelled inside the vehicle and hurt someone if the airbags inflate.



**Do not attach accessories on or near the side airbags.** They can interfere with the proper operation of the airbags or hurt someone if an airbag inflates.

**Do not attach any objects to the side windows or roof pillars.** They can interfere with the proper operation of the side curtain airbags.

**Do not cover or replace the front seat-back covers.** This can prevent your side airbags from properly deploying during a side impact.

### **⚠ WARNING**

An open glove box can cause serious injury to your passenger in a crash, even if the passenger is wearing the seat belt.

Always keep the glove box closed while driving.

### ■ Airbag System Indicators

If a problem occurs in the airbag system, the SRS indicator comes on and a message appears on the driver information interface.

#### Supplemental Restraint System (SRS) Indicator

If the indicator comes on at any other time besides vehicle start-up or does not come on at all, have the system checked by a dealer as soon as possible. If you don't, your airbags and seat belt tensioners may not work properly when they are needed.



### **⚠ WARNING**

Ignoring the SRS indicator can result in serious injury or death if the airbag systems or tensioners do not work properly.

Have your vehicle checked by a dealer as soon as possible if the SRS indicator alerts you to a possible problem.

#### Passenger Airbag Off Indicator

The indicator comes on to alert you that the front passenger's front airbag has been turned off. This occurs when the front passenger's weight sensors detect 65 lbs (29 kg) or less, the weight of an infant or small child, on the seat.

Children age 12 or under should always ride properly restrained in a back seat.

If the front passenger's seat is empty, the indicator will come on and, in the event of a crash, the front passenger's airbag will not deploy. The front passenger's knee airbag will not deploy either.

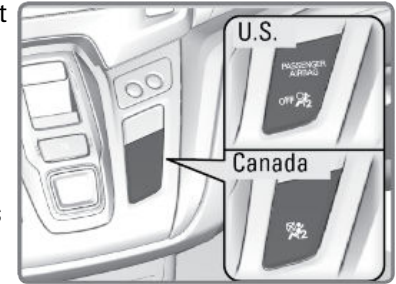

To ensure the passenger is detected properly, confirm that:

- There is no child seat or other object pressing against the rear of the seat-back.
- There is no rear passenger pushing or pulling on the back of the front passenger's seat.
- The front seat or seat-back is not forced back against an object on the seat or floor behind it.
- There is no object placed under or beside the front passenger's seat.
- The occupant is sitting in an upright position and the seat-back is not excessively reclined.
- The occupant is not leaning against the door or center console.
- The occupant's feet are placed on the floor in front of them.
- There are no objects hanging from the front passenger's seat.
- Only small, lightweight objects are in the seat-back pocket.

If none of these conditions exist, have your vehicle checked by a dealer as soon as possible.

The passenger airbag off indicator may come on and go off repeatedly if the total weight on the seat is near the airbag cutoff threshold.

### ■ Airbag System Components

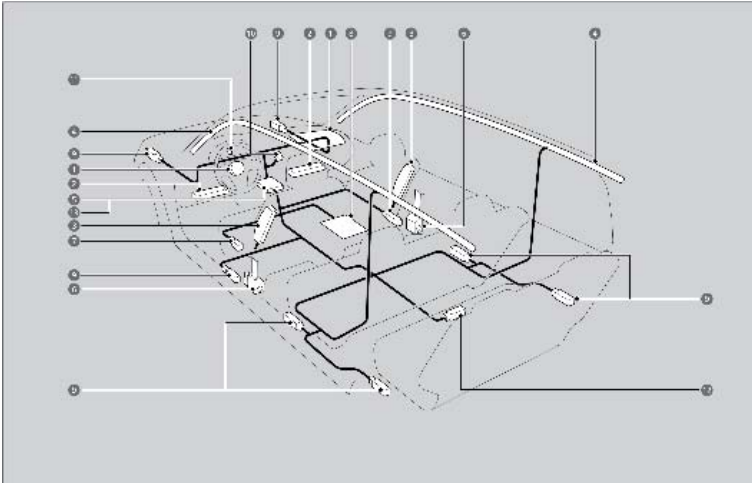

1. Two SRS (Supplemental Restraint System) front airbags. The driver's airbag is stored in the center of the steering wheel; the front passenger's airbag is stored in the dashboard. Both are marked **SRS AIRBAG**.
2. Two front knee airbags. The driver's knee airbag is stored under the steering column; the front passenger's knee airbag is stored under the glove box. Both are marked **SRS AIRBAG**.
3. Two side airbags, one for the driver and one for a front passenger. The airbags are stored in the outer edges of the seat-backs. Both are marked **SIDE AIRBAG**.
4. Two side curtain airbags, one for each side of the vehicle. The airbags are stored in the ceiling, above the side windows. The front and rear pillars are marked **SIDE CURTAIN AIRBAG**.
5. An electronic control unit that, when the vehicle is on, continually monitors information about the various impact sensors, seat and buckle sensors, rollover sensor, airbag activators, seat belt tensioners, and other vehicle information. During a crash event the unit can record such information.
6. Automatic front seat belt tensioners. The driver's and front passenger's seat belt buckles incorporate sensors that detect whether or not the belts are fastened.
7. A driver's seat position sensor. This sensor determines the optimal force at which the airbag will deploy in a crash.
8. Weight sensors in the front passenger's seat. The front passenger's airbag will be turned off if the weight on the seat is about 65 lbs (29 kg) or less (the weight of an infant or small child).

9. Impact sensors that can detect a moderate-to-severe front or side impact.
10. An indicator on the dashboard that alerts you that the front passenger's front airbag has been turned off.
11. An indicator on the instrument panel that alerts you to a possible problem with the airbag system or seat belt tensioners.
12. Safing sensor.
13. A rollover sensor that can detect if your vehicle is about to roll over and signal the control unit to deploy both side curtain airbags.

#### ■ Airbag Care

You do not need to, and should not, perform any maintenance on or replace any airbag system components yourself. However, you should have your vehicle inspected by a dealer in the following situations:

##### When the airbags have deployed

If an airbag has inflated, the control unit and other related parts must be replaced. Similarly, once an automatic seat belt tensioner has been activated, it must be replaced.

##### When the vehicle has been in a moderate-to-severe collision

Even if the airbags did not inflate, have your dealer inspect the following: the driver's seat position sensor, weight sensors in the passenger's seat, front seat belt tensioners, and each seat belt that was worn during the crash.

##### Do not remove or modify a front seat without first consulting a dealer

This would likely disable or affect the driver's seat position sensor or the weight sensors in the passenger's seat. If it is necessary to remove or modify a front seat to accommodate a person with disabilities, contact a Honda dealer. For U.S. vehicles, call Honda Automobile Customer Service at (800) 999-1009. For Canadian vehicles, call Honda Canada Customer Relations at (888) 946-6329.

#### Child Safety

Each year, many children are injured or killed in vehicle crashes because they are either unrestrained or not properly restrained. In fact, vehicle collisions are the number one cause of death of children ages 12 and under.

The National Highway Traffic Safety Administration and Transport Canada recommend that all children ages 12 and under be properly restrained in a rear

seat. Some states or provinces/territories have laws restricting where children may ride.

To reduce the number of child deaths and injuries, every state, Canadian province, and territory requires that infants and children be properly restrained when they ride in a vehicle.

#### ■ Protecting Child Passengers – Important Considerations

- An inflating front or side airbag can injure or kill a child sitting in the front seat.
- A child in the front seat is more likely to interfere with the driver's ability to safely control the vehicle.
- Statistics show that children of all sizes and ages are safer when they are properly restrained in a rear seat.
- Any child who is too small to wear a seat belt correctly must be restrained in an approved child seat that is properly secured to the vehicle using either the lap belt portion of the lap/shoulder belt or the lower anchors of the LATCH system.
- Never hold a child on your lap because it is impossible to protect them in the event of a collision.
- Never put a seat belt over yourself and a child. During a crash, the belt would likely press deep into the child and cause serious or fatal injuries.
- Never let two children use the same seat belt. Both children could be very seriously injured in a crash.
- Do not allow children to operate the doors, windows, or seat adjustments.
- Do not leave children in the vehicle unattended, especially in hot weather when the inside of the vehicle can get hot enough to kill them. They could also activate vehicle controls, causing it to move unexpectedly.

#### ⚠ WARNING

Children who are unrestrained or improperly restrained can be seriously injured or killed in a crash.

Any child too small for a seat belt should be properly restrained in a child seat. A larger child should be properly restrained with a seat belt, using a booster seat if necessary.

#### ⚠ WARNING

Allowing a child to play with a seat belt or wrap one around their neck can result in serious injury or death.

Instruct children not to play with any seat belt and make sure any unused seat belt a child can reach is buckled, fully retracted, and locked.

#### ■ Protecting Infants

An infant must be properly restrained in a rear-facing, reclining child seat until the infant reaches the seat maker's weight or height limit for the seat, and the infant is at least one year old. Many experts recommend use of a rear-facing seat for a child up to two years old if the child's height and weight are appropriate for a rear-facing seat.

Child seats must be placed and secured in a rear seating position. Rear-facing child seats should never be installed in a forward-facing position. When properly installed, a rear-facing child seat may prevent the driver or a front passenger from moving their seat all the way back, or from locking their seat-back in the desired position.

Make sure that there is no contact between the child seat and the seat in front of it. It can also interfere with proper operation of the front passenger's advanced front airbag system. If this occurs, we recommend that you install the child seat directly behind the front passenger's seat, move the seat as far forward as needed, and leave it unoccupied. Or, you may wish to get a smaller rear-facing child seat.



#### ⚠ WARNING

Placing a rear-facing child seat in the front seat can result in serious injury or death during a crash.

Always place a rear-facing child seat in the rear seat, not the front.

#### ■ Protecting Smaller Children

If a child is at least one year old and within the weight range indicated by the child seat manufacturer, the child should be properly restrained in a firmly secured forward-facing child seat.

We strongly recommend placing a forward-facing child seat in a rear seating position. Placing a forward-facing child seat in the front seat can be hazardous, even with advanced front airbags that automatically turn the

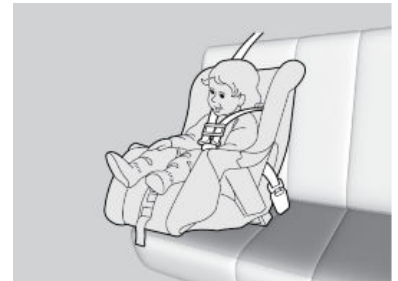

passenger's front airbag off. A rear seat is the safest place for a child.

### **⚠ WARNING**

Placing a forward-facing child seat in the front seat can result in serious injury or death if the front airbag inflates.

If you must place a forward-facing child seat in front, move the vehicle seat as far back as possible, and properly restrain the child.

#### ■ **Selecting a Child Seat**

Most child seats are LATCH-compatible (Lower Anchors and Tethers for CHildren). Some have a rigid-type connector, while others have a flexible-type connector. Both are equally easy to use. Some existing and previously owned child seats can only be installed using the seat belt. Whichever type you choose, follow the child seat manufacturer's use and care instructions as well as the instructions in this guide. Proper installation is key to maximizing your child's safety.

In seating positions and vehicles not equipped with LATCH, a LATCH compatible child seat can be installed using the seat belt and a top tether for added security. This is because all child seats are required to be designed so that they can be secured with a lap belt or the lap part of a lap/shoulder belt. In addition, the child seat manufacturer may advise that a seat belt be used to attach a LATCH-compatible seat once a child reaches a specified weight. Please read the child seat owner's manual for proper installation instructions.

#### **Important considerations when selecting a child seat**

Make sure the child seat meets the following three requirements:

- The child seat is the correct type and size for the child.
- The child seat is the correct type for the seating position.
- The child seat is compliant with Federal Motor Vehicle Safety Standard 213 or Canadian Motor Vehicle Safety Standard 213.

#### ■ **Installing a LATCH-Compatible Child Seat**

A LATCH-compatible child seat can be installed in each of the second and third row seats except for the third row center seat. A child seat is attached to the lower anchors with either the rigid or flexible type of connectors.

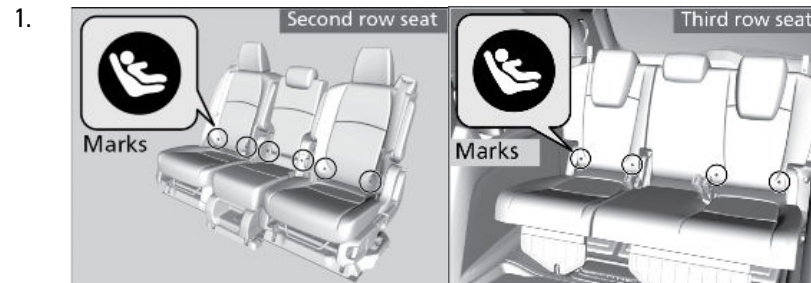

Locate the anchor marks affixed to the base of the seat cushion.

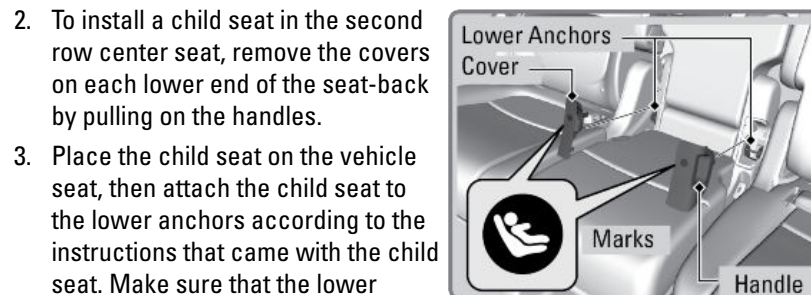

To install a child seat in the second row center seat, remove the covers on each lower end of the seat-back by pulling on the handles.

3. Place the child seat on the vehicle seat, then attach the child seat to the lower anchors according to the instructions that came with the child seat. Make sure that the lower anchors are not obstructed by the seat belt or any other object.

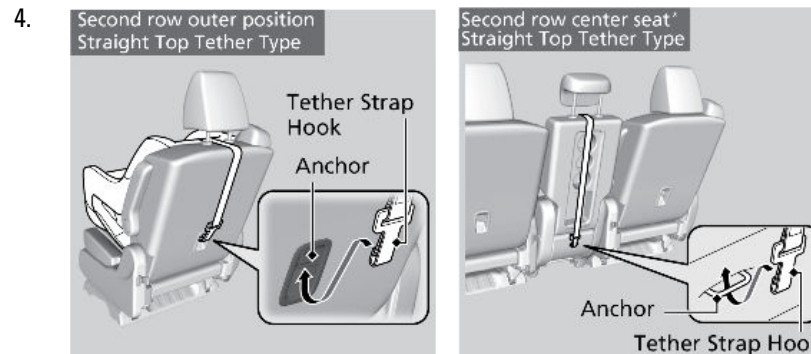

Tighten the tether strap as instructed by the child seat manufacturer.

5. Make sure the child seat is firmly secured by rocking it forward and back and side to side; little movement should be felt.

- Make sure any unused seat belt that a child can reach is buckled, the lockable retractor is activated, and the belt is fully retracted and locked.

**⚠ WARNING**

Never attach two child seats to the same anchor. In a collision, one anchor may not be strong enough to hold two child seat attachments and may break, causing serious injury or death.

**⚠ WARNING**

Do not use the lower inner anchors of the outer rear seats to secure a LATCH-compatible child seat to the rear center seat, unless the manufacturer's instructions for that system permit the use of inner anchors with the stated spacing.

■ **Installing a Child Seat with a Lap/Shoulder Seat Belt**

A child seat can be installed with a lap/shoulder belt in any rear seat or, if absolutely necessary, the front passenger seat.

- Place the child seat on the vehicle seat.
- Route the seat belt through the child seat according to the seat manufacturer's instructions, and insert the latch plate into the buckle. Insert the latch plate fully until it clicks.
- Slowly pull the shoulder part of the belt all the way out until it stops. This activates the lockable retractor.



- Let the seat belt completely wind up into the retractor, then try to pull it out to make sure the retractor is locked. If you are able to pull the shoulder belt out, the lockable retractor is not activated. Pull the seat belt all the way out, and repeat steps 3 – 4.
- Grab the shoulder part of the seat belt near the buckle, and pull up to remove any slack from the lap part of the belt. When doing this, place your weight on the child seat and push it into the vehicle seat.
- Make sure the child seat is firmly secured by rocking it forward and back and side to side; less than one inch of movement should occur near the seat belt.
- Make sure any unused seat belt that a child can reach is buckled, the lockable retractor is activated, and the belt is fully retracted and locked.

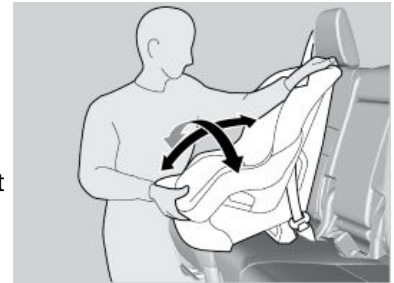

To deactivate a lockable retractor, release the buckle and allow the seat belt to wind up all the way.

■ **Adding Security with a Tether**

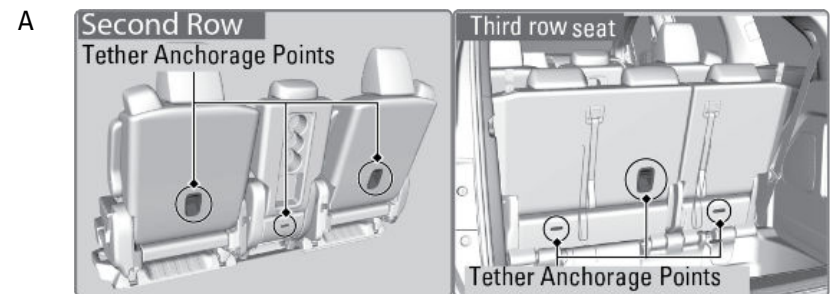

tether anchorage point is provided behind each rear seating position. If you have a child restraint system that comes with a tether but can be installed with a seat belt, the tether may be used for additional security.

## 1. Adjust head restraint

**For outer positions:** Raise the outer head restraint to its highest position, then route the tether strap between the head restraint legs. Make sure the strap is not twisted.

**For the center position:** Lower the center head restraint to its lowest position, then route the tether strap over the head restraint. Make sure the strap is not twisted.

2. Secure the tether strap hook onto the anchor.
3. Tighten the tether strap as instructed by the child seat manufacturer.

**NOTICE**

Always use a tether for forward facing child seats when using the seat belt or lower anchors.

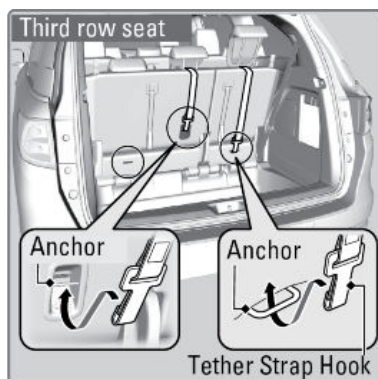
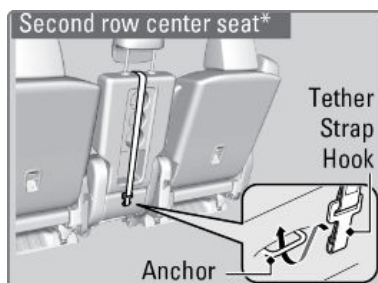
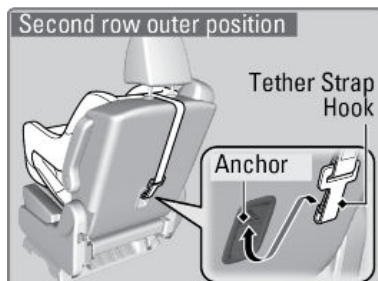
■ **Protecting Larger Children**

When a child is too big for a child seat, secure the child in a rear seat using the lap/shoulder seat belt.

Have the child sit upright and all the way back, then ensure the following:

- The child's knees bend comfortably over the edge of the seat.
- The shoulder belt crosses between the child's neck and arm.
- The lap part of the seat belt is as low as possible, touching the child's thighs.
- The child can stay seated for the whole trip.



If a lap/shoulder belt cannot be used properly, position the child in a booster seat in a rear seating position. For the child's safety, check that the child meets the booster seat manufacturer's recommendations.

Some U.S. states and Canadian provinces/territories require children to use a booster seat until they reach a given age or weight (e.g., 6 years or 60 lbs). Be sure to check current laws in the state or province/territory where you intend to drive.

**⚠ WARNING**

Allowing a child age 12 or under to sit in the front can result in injury or death if the passenger's front airbag inflates.

If a larger child must ride in front, move the vehicle seat as far to the rear as possible, have the child sit up properly and wear the seat belt properly, using a booster seat if needed.

**Safety Label Locations**

Safety labels are in the locations shown. They warn you of potential hazards that can cause serious injury or death. Read these labels carefully.

If a label comes off or becomes hard to read (except for the U.S. dashboard label which may be removed by the owner), contact a dealer for a replacement.

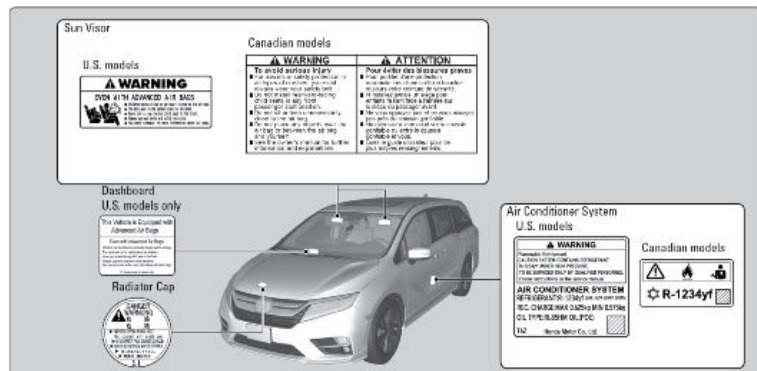

## Reporting Safety Defects

### In the U.S.

If you believe that your vehicle has a defect which could cause a crash or could cause injury or death, you should immediately inform the National Highway Traffic Safety Administration (NHTSA) in addition to notifying American Honda Motor Co., Inc.

If NHTSA receives similar complaints, it may open an investigation, and if it finds that a safety defect exists in a group of vehicles, it may order a recall and remedy campaign. However, NHTSA cannot become involved in individual problems between you, your dealer, or American Honda Motor Co., Inc.

To contact NHTSA, you may call the Vehicle Safety Hotline toll-free at 1-888-327-4236 (TTY: 1-800-424-9153); go to [safecar.gov](http://safecar.gov), or write to: Administrator, NHTSA, 1200 New Jersey Avenue, SE., Washington, DC 20590. You can also obtain other information about motor vehicle safety from [safecar.gov](http://safecar.gov).

### In Canada

If you believe that your vehicle has a defect which could cause a crash or could cause injury or death, you should immediately inform Honda Canada, Inc., and you may also inform Transport Canada.

If Transport Canada receives similar complaints, it may open an investigation, and if it finds that a safety defect exists in a group of vehicles, it may lead to a recall and remedy campaign. However, Transport Canada cannot become involved in individual problems between you, your dealer, or Honda Canada, Inc.

To contact Transport Canada's Defect Investigations and Recalls Division, you may call 1-800-333-0510. For more information on reporting safety defects or about motor vehicle safety, go to [tc.gc.ca/roadsafety](http://tc.gc.ca/roadsafety).

## INSTRUMENT PANEL

Learn about the indicators, gauges, and displays related to driving the vehicle.



Indicators briefly appear with each engine start and then go out. Red and amber indicators are most critical. Blue and green indicators are used for general information.

### Malfunction Indicators

These are the most critical indicators. If they come on and stay lit while driving or at any other time, there may be a problem. See your dealer if necessary.



#### Brake system

- Brake fluid is low.
- There is a malfunction in the brake system. Press the brake pedal lightly to check pedal pressure. If normal, check the brake fluid level when you stop. If abnormal, take immediate action. If necessary, downshift the transmission to slow the vehicle using engine braking. Have your vehicle repaired immediately.



#### Low oil pressure

Engine oil pressure is low. Stop in a safe place. Open the hood, check the oil level and add oil if necessary. If the indicator does not turn off, have your vehicle repaired immediately.



#### Charging system

The battery is not charging. Turn all electrical items off, but do not turn the vehicle off to prevent further battery discharge. Have your vehicle repaired immediately.



#### Supplemental Restraint System (SRS)

There is a problem with one of the airbag systems or seat belt tensioners.

**Smart Entry System\*1**

There is a problem with the system.

**LKAS****Lane Keeping Assist System (LKAS) \*1**

There is a problem with the system.

**Malfunction Indication Lamp (check engine light)**

The emissions control system may have a problem, or the fuel cap is missing or loose. If the indicator blinks, a misfire in the engine's cylinders is detected. Stop in a safe place and wait for the engine to cool down.

**Anti-lock Brake System (ABS)**

There is a problem with the anti-lock brake system. Your vehicle still has normal braking ability, but no anti-lock function.

**Low Tire Pressure / Tire Pressure Monitoring System (TPMS)**

- Blinks and remains on:  
Have your vehicle checked by a dealer. If the vehicle is fitted with a compact spare, get your regular tire repaired or replaced and put back on your vehicle as soon as you can.

**Vehicle Stability Assist® (VSA®) System**

There is a problem with the VSA® or hill start assist system.

**Collision Mitigation Braking System™ (CMBS™) \*1**

There is a problem with the system, the temperature inside the camera is too high or the camera or sensor is blocked.

**Road Departure Mitigation (RDM)\*1**

There is a problem with the system, the temperature inside the camera is too high, or the camera is blocked.

**Electric Power Steering (EPS)**

There is a problem with the system. Stop the vehicle in a safe place, and restart the engine.

**ACC****Adaptive Cruise Control (ACC)\*1**

There is a problem with the system.

**Condition Indicators**

These indicators may require you to perform an action.

*\*1 - If equipped*

**BRAKE**  
us**Parking Brake**

Release the parking brake before driving. You will hear a beep if you drive with it not fully released.

  
Canada**Seat Belt Reminder**

Make sure seat belts are fastened for you and all passengers. The indicator blinks and beeps sound continuously if you or your front passenger has not fastened your seat belts when you begin driving. If the indicator remains on after seat belts are fastened, see your dealer.

**Low Fuel**

Refuel as soon as possible. If the indicator blinks, there is a problem with the fuel gauge. See your dealer.

**Low Tire Pressure / Tire Pressure Monitoring System (TPMS)**

- Comes on while driving:  
Stop in a safe place, check tire pressures, and inflate tire(s) if necessary.

**System Message**

When a condition or malfunction indicator comes on, a message also appears on the driver information interface (DII). Check the display for more information.

**Immobilizer**



Your key or remote transmitter cannot be recognized by the vehicle. If the indicator blinks, you may not be able to start the engine. Turn the vehicle off, and then on again. If it continues to blink, there may be a problem with the system. See your dealer.



**On/Off Indicators**

These indicators remind you when an item is on or off.

**VSA® off****RDM off****VSA® engaged (blinks)****LKAS****LKAS on****CMBS off****ACC****ACC on**



-  Turn signals/hazards on
-  Fog lights\*1 on
-  High beams on

-  Exterior lights on
-  Auto High Beam System on
-  ECON mode on

## Driver Information Interface

Consists of several displays that provide you with useful information.

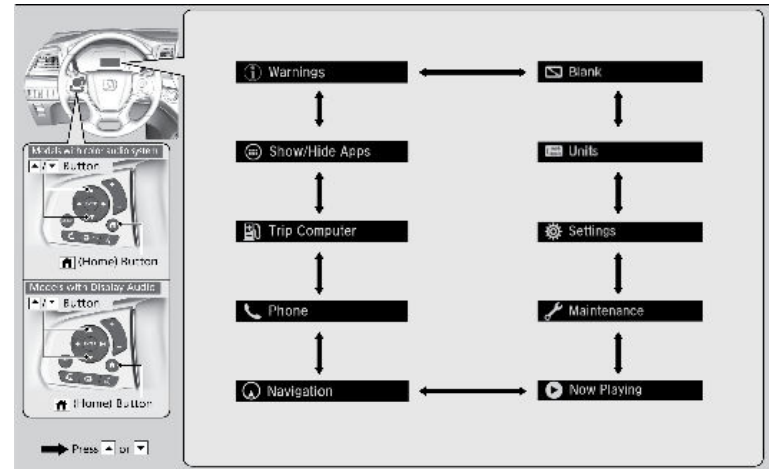

\* Not available on all models

# VEHICLE CONTROLS

Learn about the various controls necessary for operating and driving the vehicle.

## Using the Remote Transmitter

Lock or unlock the doors, tailgate, and fuel-fill door. Start and stop the engine.\*1



**Unlock button:** Press once to unlock the driver's door. Press again to unlock all doors.

**Lock button:** Press to lock the doors and tailgate. Press again for audible verification.

**Tailgate button:** Press once to unlock the tailgate.

**Panic button:** Press and hold to sound the alarm for 30 seconds. Press any button to cancel.

**Built-in key:** Slide the release knob on the back of the transmitter and pull out the built-in key.

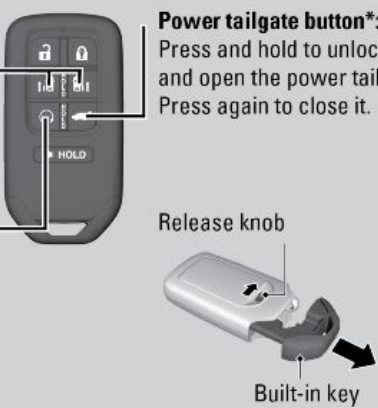

**Power sliding door buttons\*:** Press and hold to open the sliding door. Press again to stop the door during operation. Press again to close the door.

**Power tailgate button\*:** Press and hold to unlock and open the power tailgate. Press again to close it.

**Engine button\*:** After pressing the Lock button, press and hold to remotely start the engine

Release knob

Built-in key

### NOTICE

Leaving the remote transmitter in the vehicle can result in theft or accidental movement of the vehicle. Always take it with you whenever you leave the vehicle unattended.

## Smart Entry System\*1

When you carry the remote transmitter (for example, in a pocket or purse) and it is outside the vehicle and within range (about 32 inches or 80 cm), you can lock or unlock the doors, and the tailgate without handling the transmitter.

### ■ Unlocking/Locking the Doors

**To unlock:** Grab the driver's door handle to unlock the driver's door. Grab the front passenger's door handle or rear door handle to unlock all the doors and the tailgate. You can customize this feature's behavior.



**To lock:** Press the door lock button on either front door handle. If the remote transmitter is inside the vehicle, the doors will not lock.



### ■ Walk Away Auto Lock®

When you walk away from the vehicle while carrying the remote transmitter, the doors can automatically lock if the following conditions are met:

- The remote transmitter is within a range of 5 feet (1.5 m).
- All doors and the trunk are closed.
- There is not an additional remote transmitter inside the vehicle.

Follow these steps:

\*1 - If equipped

\*1 - If equipped

1. Exit the vehicle, close the door and stay near it. Listen for a beep. The system is activated.
2. Walk at least 5 feet (1.5 m) away.
3. Listen for a beep and look for the lights to flash. The doors lock.

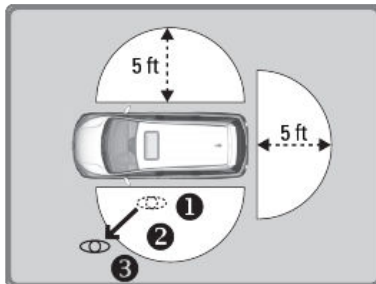

■ Customizing Door Lock & Unlock Settings

Customize the auto door lock and door unlock settings to your preference. Begin with the vehicle off.

Models with Color Audio

Customizing Door Lock Settings

See Customized Features.

Customizing Door Unlock Settings

See Customized Features.

Models with Display Audio

See Customized Features.

Door Operation

Use several methods to lock or unlock the doors.

■ Using the Lock Tab

**To unlock:** When you unlock either front door using the lock tab, the specific door (driver's or passenger's) unlocks.

**To lock:** When you lock the door using the lock tab on the driver's door, all the other doors and the tailgate lock at the same time. When you lock the door using the lock tab on the front passenger's door, only that door locks.

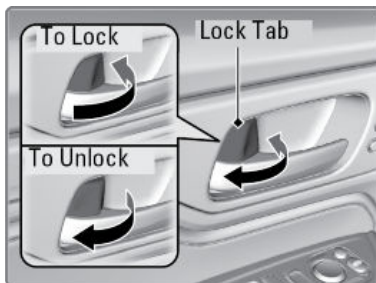

■ Using the Front Door Inner Handle

Pull the front door inner handle. The door unlocks and opens in one motion. Unlocking and opening the driver's door from the inner handle unlocks all other doors.

Do not pull a front door inner handle while the vehicle is moving.

Unlocking and opening the driver's door from the inner handle unlocks all the other doors and the trunk.



■ Using the Master Door Lock Switch

**To unlock:** Press the unlock side of the switch to unlock all doors and the tailgate.

**To lock:** Press the lock side of the switch to lock all doors and the tailgate.

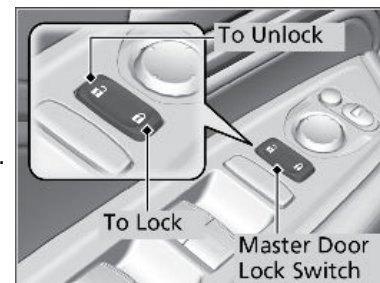

■ Childproof Door Locks

The childproof door locks prevent the rear doors from being opened from the inside regardless of the position of the lock tab.

Slide the lever in the rear door to the lock position, and close the door.

Open the door using the outer door handle.

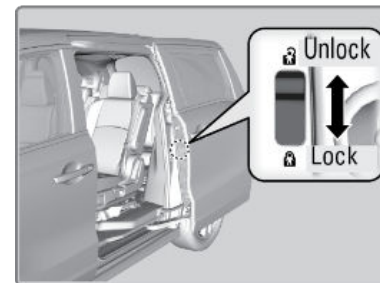

■ **Opening/Closing the Sliding Doors**

From the outside, pull the outer door handle and slide the door all the way to the front or rear.

From the inside, grab the inner door handle and slide the door all the way to the front or rear.

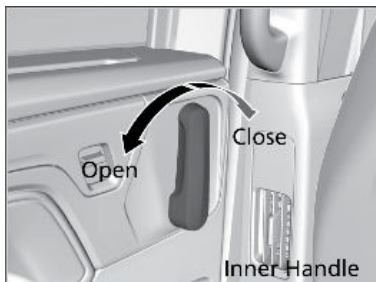
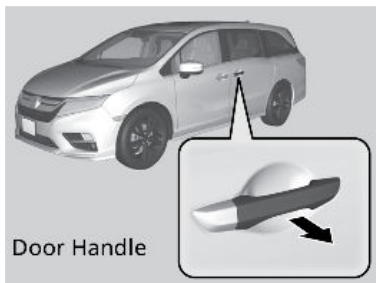

■ **Power Sliding Doors\*1**

When the vehicle is OFF or the remote engine start mode is active, the power sliding doors operate when:

- The power sliding door switch is ON (as shown) and
- The power sliding door is unlocked and
- The fuel fill door is closed (for driver's side sliding door).

When the vehicle is ON, the power sliding doors operate when:

- The shift position is P and
- The brake pedal is depressed or the electric parking brake is applied and
- You use the power sliding door switches on the dashboard.

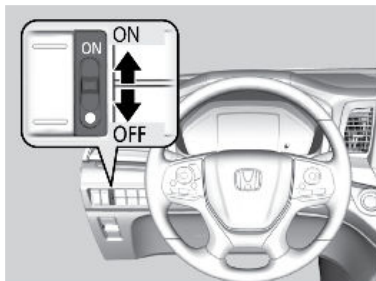

From the inside

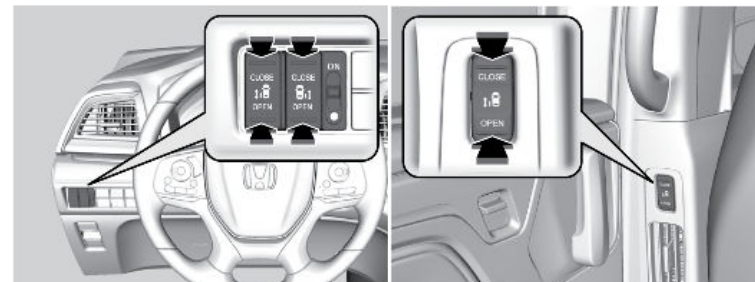

Press OPEN on the power sliding door button for the desired door side.

Press CLOSE to close the door.

While a power sliding door is in operation, you can press the button again to stop it from opening or closing. Press the button again to resume operation.

A sliding door will not open fully if the window is open more than 3 inches (8 cm). Close the door, close the window, and open the door again.

The driver's side sliding door will not open if the fuel fill door is opened.

**Note:** Closing a sliding door while any part of a passenger is in the door's path can cause serious injury.

Make sure all passengers are clear of the doorway before closing a sliding door.

**Tailgate Operation**

Use these methods to operate the tailgate.

■ **Power Tailgate Button**

To open or close the power tailgate, press the power tailgate button for about one second.

If you press the button again while the power tailgate is moving, it will stop. Press the button for about one second, and the power tailgate will reverse direction.

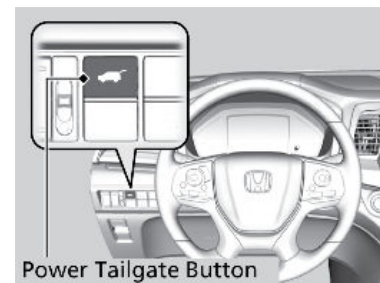

\*1 - If equipped

■ **Power Tailgate Outer Handle**

**Automatic Operation**

If you press the outer handle of the tailgate for no longer than one second, the tailgate opens automatically.

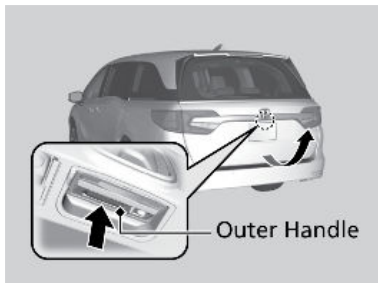

**Manual Operation**

If you want to open the tailgate manually, press the button for more than one second.

■ **Programmable Tailgate Position**

You can set the maximum opening of the tailgate to suit your needs.

1. Manually adjust the tailgate to your desired position.
2. Press and hold the tailgate inner button until you hear one long and two short beeps.

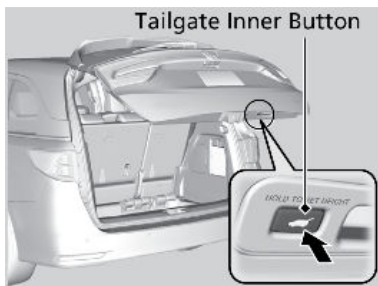

■ **Power Tailgate Inner Button**

Press the button on the tailgate to close the power tailgate.

If you press the button again while the power tailgate is moving, it will stop. Press and release the button again, and the power tailgate will reverse direction.



■ **Power Tailgate Hands Free Access\*1**

Use a forward and back kicking motion under the center of the rear bumper to open or close the power tailgate while carrying the keyless access remote.

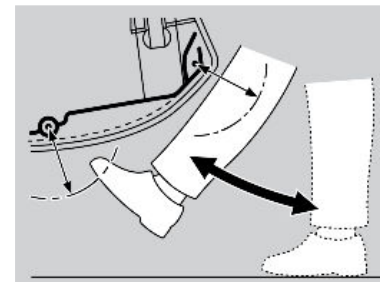
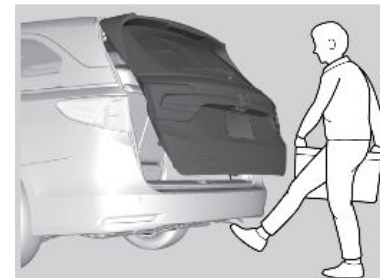

**Power Window Operation**

The power windows can be opened and closed by using the switches on the doors when the vehicle is on. The switches on the driver's side can be used to open and close all the windows.

■ **Automatic Operation**

**To open:** Push the switch down firmly.

**To close:** Pull the switch up firmly.

The window opens or closes completely. To stop the window at any time, push or pull the switch again briefly.

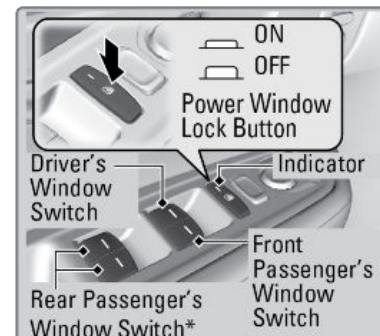

\*1 - If equipped

■ **Manual Operation**

**To open:** Push the switch down lightly.

**To close:** Pull the switch up lightly.

Release the switch when the windows reach the desired position.

■ **Power Window Lock**

Push in the power window lock button so only the driver's window can be operated.

**⚠ WARNING**

Closing a power window on someone's hands or fingers can cause serious injury.  
Make sure your passengers are away from the windows before closing them.

**Power Moonroof Operation\*1**

The moonroof can be opened and closed when the vehicle is on by using the switch on the ceiling.

■ **Automatic Operation**

**To open:** Firmly push the switch back, then release.

**To close:** Firmly push the switch forward, then release.

The moonroof opens or closes completely. To stop the moonroof at any time, push the switch briefly.

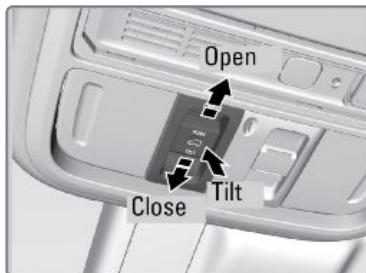

■ **Manual Operation**

**To open:** Push the switch down lightly.

**To close:** Pull the switch up lightly.

Release the switch when the window reaches the desired position.

The moonroof opens or closes completely. To stop the moonroof at any time, push the switch briefly.

■ **Moonroof Tilt**

**To tilt:** Push the center of the switch.

**To close:** Push the switch forward firmly, then release.

**⚠ WARNING**

Closing the moonroof on someone's hands or fingers can cause serious injury.  
Make sure your passengers are away from the moonroof before closing it.

**Interior and Exterior Lights**

Operate interior and exterior lights when the vehicle is on or off.

■ **Brightness Control**

Adjust instrument panel brightness when the vehicle is on.

**To brighten:** Turn the knob to the right.

**To dim:** Turn the knob to the left.

A beep sounds when the brightness reaches its minimum or maximum.

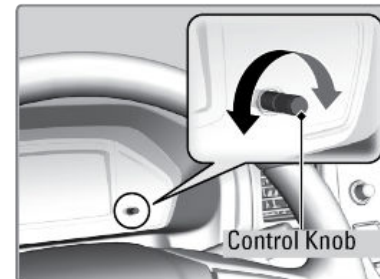

■ **Interior Lights**

**ON position:** Interior lights remain on.

**Door-activated position:** Interior lights come on when any of the doors are opened, the driver's door is unlocked, or the vehicle is turned off.

**OFF position:** Interior lights remain off.

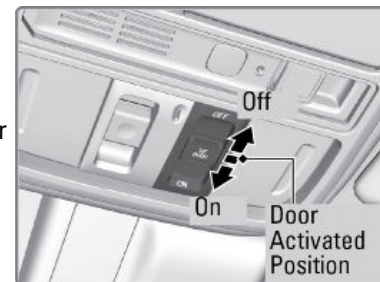

■ **Map Lights**

Press the front map lights to turn on or off.



\*1 - If equipped

Press the second or third row map lights to turn on or off when the front interior light switch is in the door-activated position.

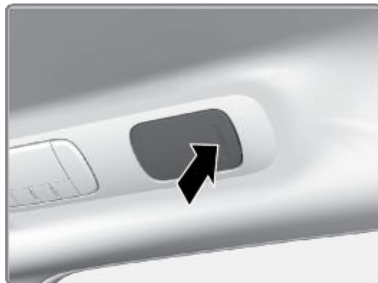

■ Exterior Lights

Rotate the switches on the lever to operate the exterior lights. Push the lever forward to turn on the high beams. Return the lever to its original position for low beams.

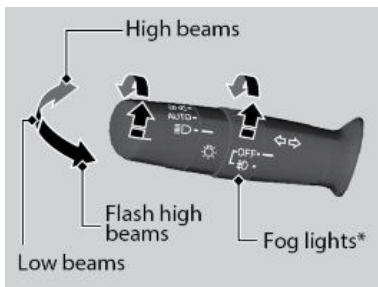

**OFF:** All exterior lights are off.

 Turn on exterior lights except headlights.

**AUTO:** Turn on the automatic lighting feature. Headlights turn on or off depending on ambient brightness when the vehicle is on. Headlights automatically come on after the wipers are engaged for a certain time. The headlights come on when you unlock a door in dark areas with the headlight switch in AUTO.

 Turn on all exterior lights including headlights.

 Turn fog lights\*<sup>1</sup> on or off.

■ Cargo Area Lights

Located on the rear ceiling in front of the tailgate.

**ON position:** Cargo lights remain on.

**OFF position:** Cargo area lights remain off.



One-Touch Turn Signal

Use this quick and convenient method to signal a lane change.

Lightly push the turn signal lever up or down for a three-blink sequence.

For a continuous signal, push the lever up or down until it locks into place.

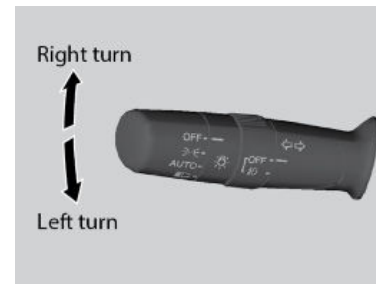

Auto High Beam System\*<sup>1</sup>

Automatically changes the low beam headlights to high beam headlights when necessary.

■ How It Works

When you are driving at night above 45mph (72 km/h) and the headlight lever is in the low beam position with the switch rotated to AUTO, the system changes between low and high beams depending on the light source ahead of you.

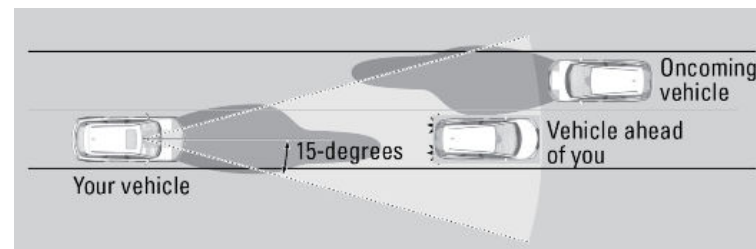

\*1 - If equipped

\*1 - If equipped

If a vehicle is detected ahead of you, the headlights stay in low beams. If the system does not detect any vehicles ahead of you, the headlights change to high beams.

Certain conditions, such as weather and brightness of other vehicles' lights, can affect system operation.

■ **Turning the System On or Off**

Make sure the headlight lever is in the low beam position with the switch rotated to the AUTO position.

The auto high beam system indicator comes on.

**To disable the system:** Pull and hold the headlight lever toward you for about 40 seconds, until the indicator flashes twice.

**To enable the system:** Pull and hold the headlight lever toward you for about 30 seconds, until the indicator flashes once.



**To temporarily cancel operation,** do either of the following:

- Flash the high beams by moving the lever toward you. Flash the high beams again to resume auto high beam operation.
- Engage high beams by moving the lever into the high beam position. Return the lever to the low beam position to resume auto high beam operation.

If you find the timing of beam changes inconvenient for driving, change the beams manually.

**For the system to work properly:**

- Do not place an object that reflects light on the dashboard.
- Keep the windshield around the camera clean. When cleaning the windshield, be careful not to apply windshield cleanser to the camera lens.
- Do not attach an object, sticker or film in the area around the camera.
- Do not touch the camera lens.

If the camera receives a strong impact or requires repair, consult a dealer.

If you see the message "Some Driver Assist Systems Cannot Operate: Clean Front Windshield," park your vehicle in a safe place. Wipe away debris blocking the windshield, then start driving again. If the message remains

even after driving for a while with the clean windshield, have your vehicle checked by a dealer.

If you see a message that the camera is too hot, use the climate control system to cool the interior. Defroster mode will direct airflow toward the camera.

**Wiper Operation**

The windshield wipers and washers can be used when the vehicle is on.

■ **Front Wipers**

Move the wiper lever up or down to the desired position.



■ **Intermittent (INT) Wipers\*1**

When you move the lever to the INT position, the wipers operate based on the delay adjustment.

Rotate the adjustment ring to adjust the wiper delay.

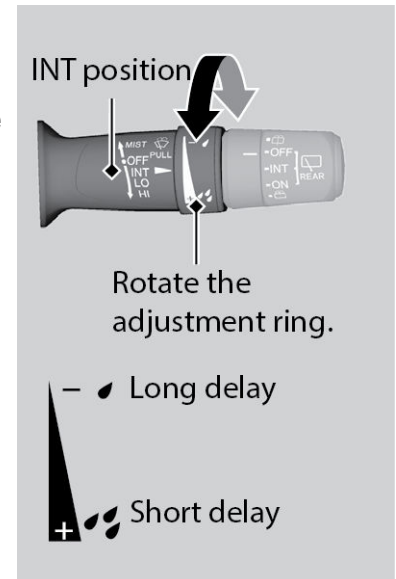



## Adjusting the Seats

Make seat adjustments before driving to ensure the best comfort and safety.

### ■ Adjusting the Front Seats

Adjust the driver's seat as far back as possible while allowing you to maintain full control of the vehicle. You should be able to sit upright and well back in the seat, adequately press the pedals without leaning forward, and grip the steering wheel comfortably. The passenger's seat should be adjusted so that it is as far back from the front airbag in the dashboard as possible.

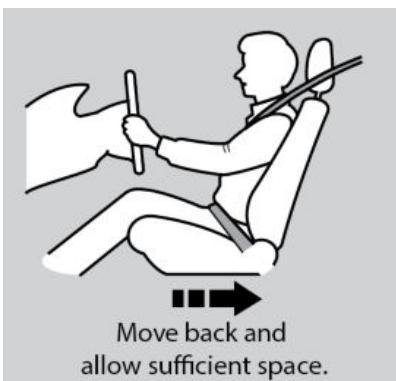

The National Highway Traffic Safety Administration and Transport Canada recommend that drivers allow at least 10 inches (25 cm) between the center of the steering wheel and the chest.

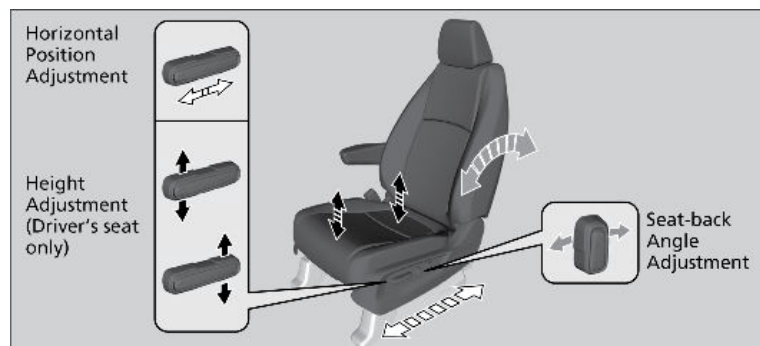

### ⚠ WARNING

Sitting too close to a front airbag can result in serious injury or death if the front airbags inflate.

Always sit as far back from the front airbags as possible while maintaining control of the vehicle.

### ⚠ WARNING

Reclining the seat-back too far can result in serious injury or death in a crash.

Adjust the seat-back to an upright position, and sit well back in the seat.

### ⚠ WARNING

Sitting improperly or out of position can result in serious injury or death in a crash.

Always sit upright, well back in the seat, with your feet on the floor.

## Driving Position Memory System\*1

You can store two driver's seat (except for power lumbar) and door mirror positions with the driving position memory system.

When you unlock and open the driver's door with a remote transmitter, or smart entry system, door mirrors adjust to one of the two preset positions and the seat adjusts to retracted positions of one of the two preset positions automatically.



### Storing a Position in Memory

1. Adjust the seat and mirrors to your preferred positions.
2. Press SET.
3. Press and hold memory button 1 or 2 within 5 seconds of pressing the SET button.

You will hear two beeps when the memory is set.

4. Press one of the memory buttons to recall previously stored positions.

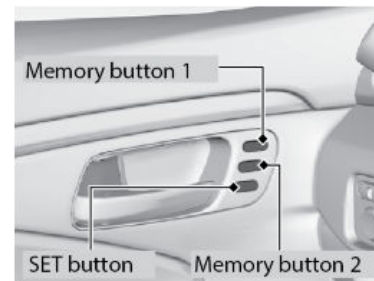

### Adjusting the Head Restraints

Your vehicle is equipped with head restraints in all seating positions. Head restraints are most effective for protection against whiplash and other rear-impact crash injuries.

The center of the back of the occupant's head should rest against the center of the restraint. The tops of the occupant's ears should be level with the center height of the restraint.

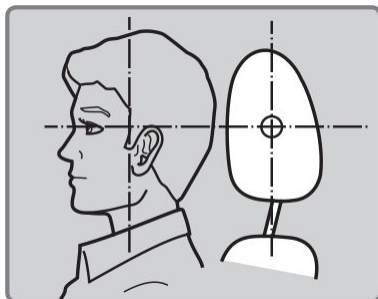

#### For a head restraint system to work properly:

- Do not hang any items on the head restraints or from the restraint legs.
- Do not place any objects between an occupant and the seat-back.
- Install each restraint in its proper location.

#### **⚠ WARNING**

Improperly positioning head restraints reduces their effectiveness and increases the likelihood of serious injury in a crash.

Make sure head restraints are in place and positioned properly before driving.

#### ■ Adjusting the Front Head Restraints

**To raise the head restraint:** Pull it upward.

**To lower the head restraint:** Push it down while pressing the release button.

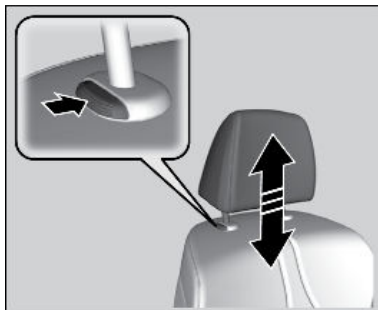

#### ■ Adjusting the Rear Head Restraints

**To raise the head restraint:** Pull it upward.

**To lower the head restraint:** Push it down while pressing the release button.

#### ■ Removing and Reinstalling the Head Restraints

Head restraints can be removed for cleaning or repair.

#### **To remove the head restraint:**

Pull the restraint up as far as it will go. Then push the release button, and pull the restraint up and out.

#### **To reinstall a head restraint:**

Insert the legs back in place, then adjust the head restraint to an appropriate height while pressing the release button. Pull up on the restraint to make sure it is locked in position.

#### **⚠ WARNING**

Failure to reinstall, or correctly reinstall, the head restraints can result in severe injury during a crash.

Always replace the head restraints before driving.

### Adjusting the Rear Seats

Adjust second row seat, access third row seats, or remove seats for carrying cargo.

#### ■ Adjusting the Second Row Passenger's Seats

Second row passenger's seats can be adjusted manually.

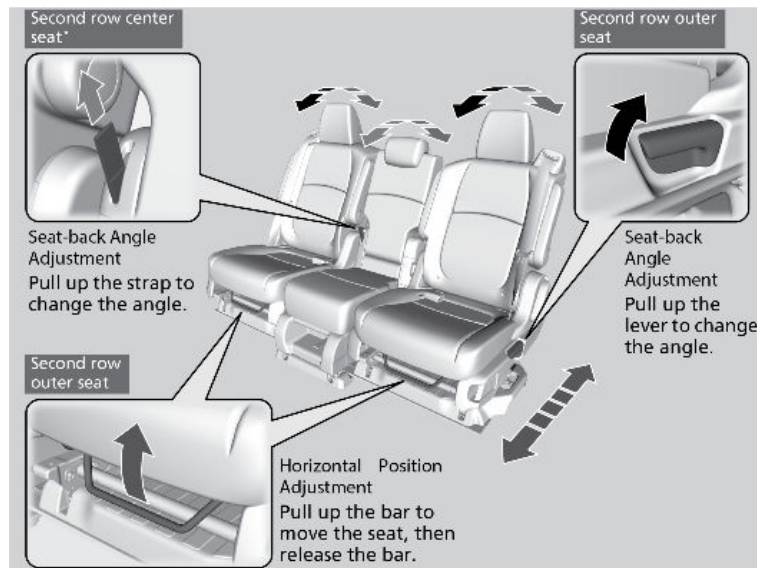

#### ■ Adjusting the Third Row Passenger's Seats

Pull up the right strap to change the angle of the right hand seat back or the left strap for the left and center seat backs.

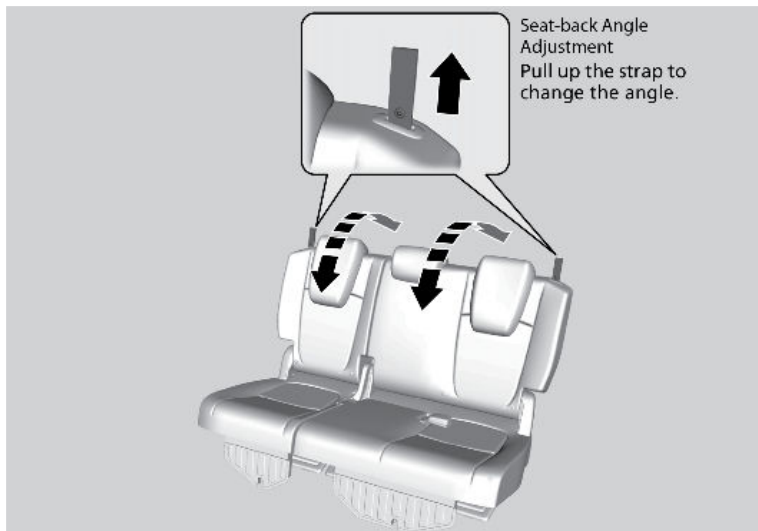

■ **Removing the Second Row Center Seat\*1**

The second row center seat can be removed to increase storage, cargo space, or passenger mobility.

1. Store the center seat belt.
2. Release the center seat belt detachable anchor (insert a key into the slot on the side of the anchor buckle) and retract the seat belt into the holder on the ceiling.
3. Pull up the adjustment strap and fold down the seat back.
4. Pull the lock release strap under the seat cushion and hold the seat back while lifting the rear of the seat.
5. Pull the seat back slightly, then pivot it upward to unhook the front of the seat from the floor.
6. Remove the seat.

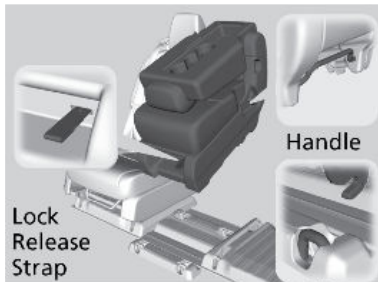

**To reinstall the seat:** First hook the front of the seat to the floor. Then push the rear of the seat back until it locks into place.

■ **Removing a Second Row Outer Seat**

Follow the steps below to remove either of the second row outer seats:

1. Remove the head restraint.

2. Move the seat to its rearmost position.
3. Fold the seat back down.
4. Pull the lock release lever and lift the rear of the seat.
5. Pull the seat back slightly, then pivot it upward.
6. Remove the seat.

**To reinstall the seat:** First hook the front of the seat to the floor. Then push the rear of the seat back until it locks into place.

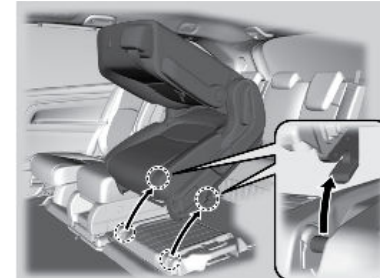
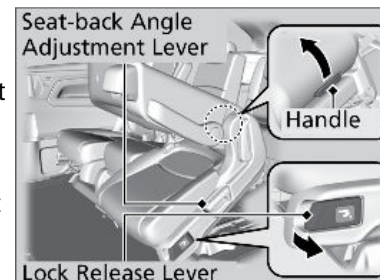

■ **Sliding the Second Row Magic Slide™ Seats\*1**

With the second row center seat removed, the second row outer seats can be moved in or out. Pull up the handle at the side of the seat, then slide the seat.



\*1 - If equipped

\*1 - If equipped

■ **Third Row Seat Access**

Pull up on the walk-in lever or pull the release strap to tilt the second row outer seat forward. Slide the whole seat forward.

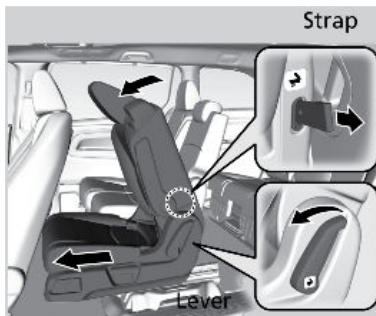

■ **Storing the One-Motion Third Row Magic Seat®**

You can store the third row seats to create a flat cargo area.

1. Release the center seat belt detachable anchor (insert a key into the slot on the side of the anchor buckle) and retract the seat belt into the holder on the ceiling.
2. Lower the head restraints to their lowest positions.
3. Pull one of the straps to release the leg lock. Keep pulling to tuck the seats and straps into the cargo area.

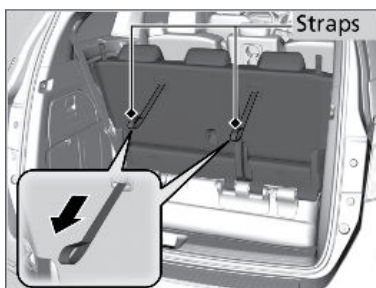

**To reinstall the seats:** Grab the handle, pull up the folded seat and pivot it forward. The front of the seat automatically locks into place. Pull the strap to return the seat back to its upright position.

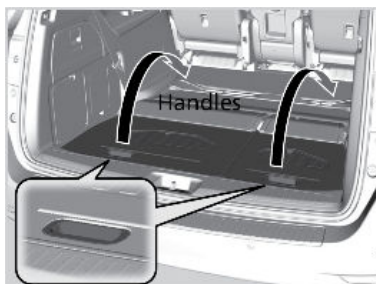

■ **Folding Down the Rear Seats**

To fold down the seat:

**Floor Mats**

Position the front and rear seat floor mats properly and anchor them. If they are not properly positioned, the floor mats can interfere with the front seat functions.

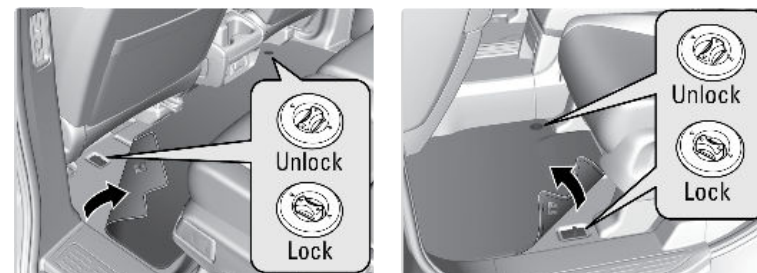

**Do not put additional floor mats on top of the anchored mats.**

**Adjusting the Steering Wheel**

The steering wheel height and distance from your body can be adjusted so that you can comfortably grip the steering wheel in an appropriate driving posture.

1. Push down the steering wheel adjustment lever.
2. Move the steering wheel up, down, in, or out.
3. Pull up the lever to lock the steering wheel in place.

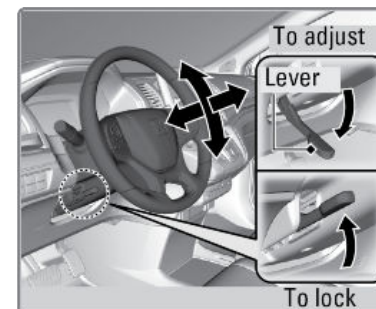

**⚠ WARNING**

Adjusting the steering wheel position while driving may cause you to lose control of the vehicle and be seriously injured in a crash. Adjust the steering wheel only when the vehicle is stopped.

**Adjusting the Mirrors**

Adjust the angle of the mirrors for the best visibility when you are sitting in the correct driving position.

■ **Rearview Mirror with Day/Night Positions\*1**

Manually adjust the position to reduce headlight glare from vehicles behind you. Flip the tab to switch between day and night positions.

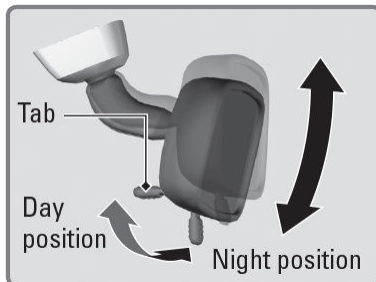

■ **Automatic Dimming Rearview Mirror\*1**

When driving after dark, the automatic dimming function reduces glare in the rearview mirror from headlights behind you. This function cancels when the shift lever is in Reverse (R).

Press the Auto button to enable or disable the feature.

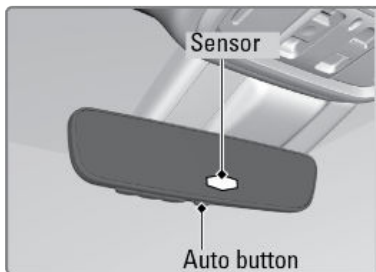

■ **Power Door Mirrors**

Adjust the power door mirrors when the vehicle is on. **L/R selector switch:** Select the left or right mirror.

**L/R selector switch:** Select the left or right mirror.

After adjusting the mirror, return the switch to the center position.

**Mirror position adjustment switch:** Press the switch left, right, up, or down to move the mirror.

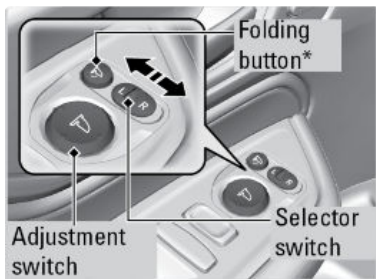

■ **Reverse Tilt Door Mirrors\*1**

To activate this feature, set the power mode to ON and slide the selector switch to the left or right side. If activated, either side door mirror can tilt downward when you shift to Reverse (R) to improve visibility on the selected side of the vehicle when reversing. The mirror returns to its original position when you shift out of Reverse.



Slide the selector switch to left or right to tilt down either side door mirror.

To enable reverse tilt, use the Vehicle Settings feature (See Customized Features)

**Homelink® Universal Transceiver\*1**

Program your vehicle to operate up to three remote-controlled devices around your home—such as garage doors, lighting, or home security systems—using the buttons on the bottom of the rearview mirror.

■ **Training a Button**

Park near the system you want to program, and follow the instructions in the flowchart below.

\*1 - If equipped

\*1 - If equipped

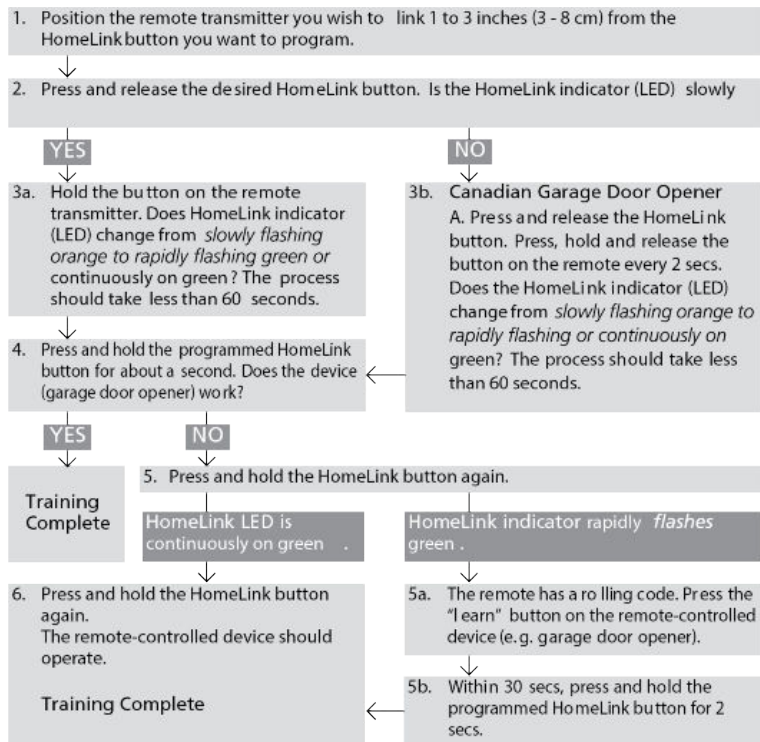

To retrain a button or erase codes, see the Owner's Manual at [owners.honda.com](http://owners.honda.com) (U.S.) or [www.myhonda.ca](http://www.myhonda.ca) (Canada). If you need help, call HomeLink at (800) 355-3515 or visit [www.homelink.com](http://www.homelink.com).

### Climate Control System

The automatic climate control system can maintain your preferred interior temperature by selecting the proper mix of heated or cooled air and fan speed. Use the buttons on the dashboard to control both front and rear operation.

#### Front Operation - Climate Control System

### Automatic Climate Control - Dual Zone Climate Control System

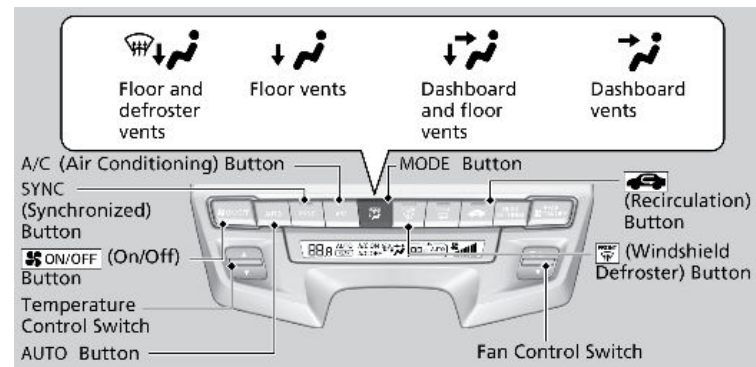

### Automatic Climate Control - Tri-Zone Climate Control System

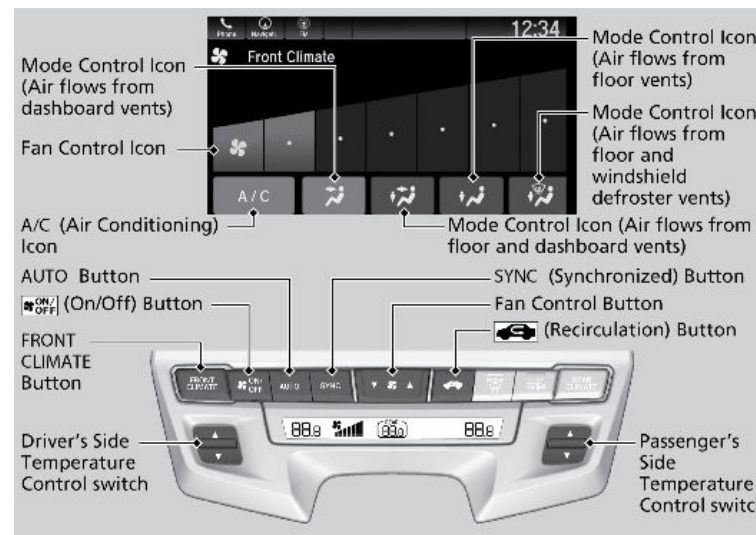

### Front Seat Heaters and Ventilation\*1

Press the seat heater or the seat ventilation\*1 button to cycle through settings. The appropriate indicator (red for heat, blue for ventilation) appears for each setting.

\*1 - If equipped

- Once - The HI setting (three indicators on)
- Twice - The MID setting (two indicators on)
- Three times - The LO setting (one indicator on)
- Four times - The OFF setting (no indicators on)

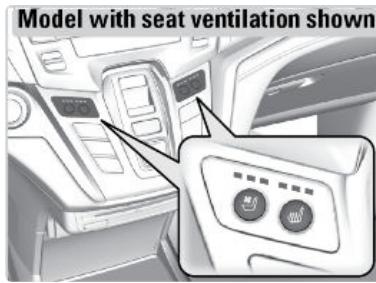

**⚠ WARNING**

Heat-induced burns are possible when using seat heaters. Persons with a diminished ability to sense temperature (e.g., persons with diabetes, lower-limb nerve damage, or paralysis) or with sensitive skin should not use the seat heaters.

**Customized Features**

The vehicle must be in Park (P) and the power mode set to ON to select Vehicle Settings. Use the interface to make and enter selections.

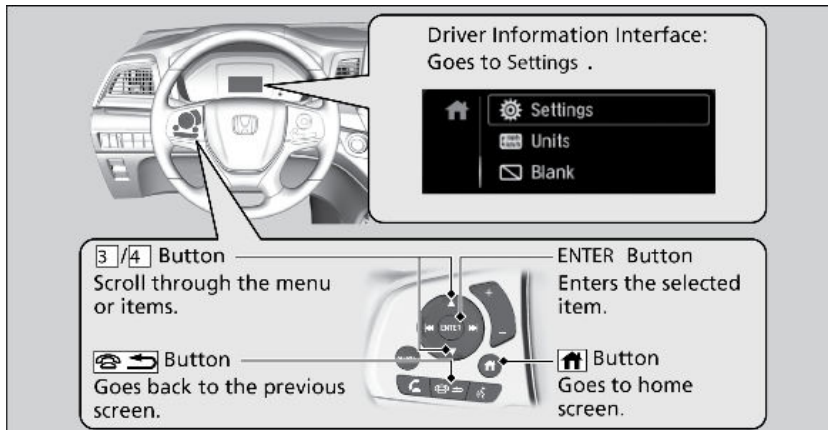

■ **How to Change a Setting**

**Models with Color Audio**

Use the selector knob to make and enter selections.

1. Press the MENU/CLOCK button.
2. Select Settings.
3. Select a setting option and make your preferred changes.

4. Press the Back button to exit the menus.

**Models with Display Audio**

1. Press the SETTINGS button.
2. Select a category.
3. Select a setting option, and make your preferred changes.
4. Press the BACK button to exit out of the menus.

**Setting the Clock**

On vehicles with navigation, the time is automatically set using GPS signals. On vehicles without navigation, use the following steps to adjust the time in the clock display.

**Models with Color Audio**

1. Press and hold the **MENU/CLOCK** button.
2. Rotate button to change the hour, then press the **MENU/CLOCK** button.
3. Rotate button to change the minute, then press the **MENU/CLOCK** button.
4. To enter the selection, rotate button, select Set, then press **MENU/CLOCK** button.



**Models with Display Audio**

1. Press the **Home** button.
2. Select **Settings**
3. Select **System**
4. Select **Date & Time**
5. Select **Set Date & Time**
6. Select **Set Time**
7. Select +/-
8. Press the **Save** button to set the time.



**HondaVAC™\*1**

Clean up dry spills and debris inside your vehicle with the in-car vacuum system.

*\*1 - If equipped*

# AUDIO AND CONNECTIVITY

Learn how to operate the vehicle's audio system.

## Basic Audio Operation

Connect audio devices and operate buttons and displays for the audio system.

### ■ USB Port

Connect a USB flash drive or other audio device, such as an iPod® or iPhone®\*14. Install the flash drive or cable connector to the USB port.

#### Models with Color Audio

The right-side port (1.0A) is for playing audio, connecting a phone, and device charging.

The left-side port (2.5A) is for device charging only.

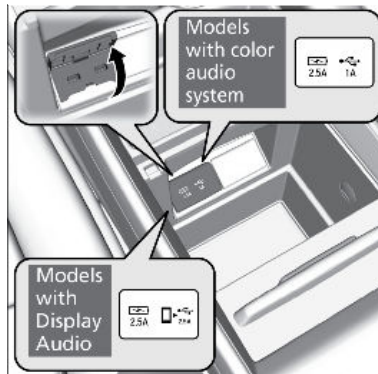

#### Models with Display Audio

The USB port (2.5A) on the right side is for charging devices, playing audio files and connecting compatible phones with Apple CarPlay or Android Auto.

The USB port (2.5A) on the left side is only for charging devices.

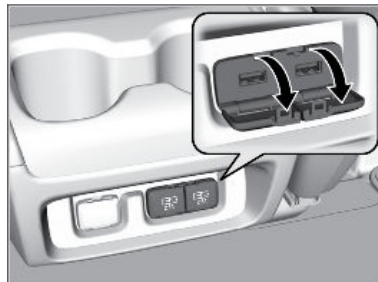

### ■ Accessory Power Socket

Open the socket cover to use power when the vehicle is on.

Power sockets are located in the front console and the driver's side rear cargo area and the third-row seat\*1.



### NOTICE

Do not insert an automotive type cigarette lighter element. This can overheat the power socket.

### ■ Audio Remote Controls\*1

You can operate certain functions of the audio system using the steering wheel controls.

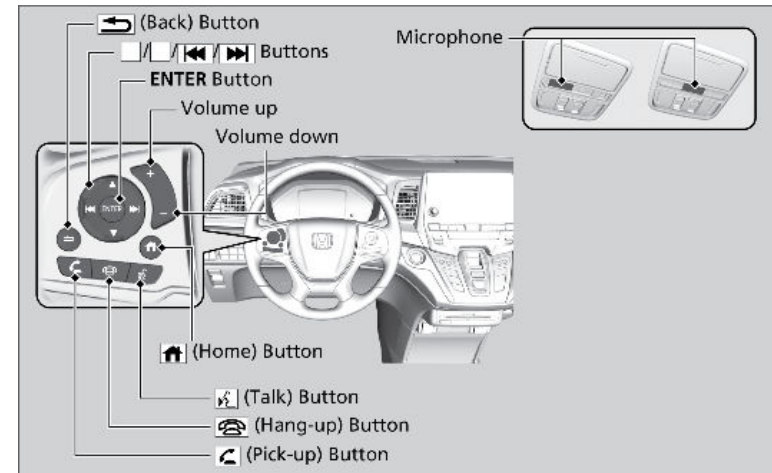

### ■ Adjusting the Sound

Adjust various sound settings.

#### Models with Color Audio

Use the selector knob to make and enter selections.

\*14 - iPod and iPhone are trademarks of Apple, Inc.

\*1 - If equipped



1. Press the Sound button.
2. Select a sound mode to change, and adjust it using the selector knob.
3. Press the Back button to exit the menu.

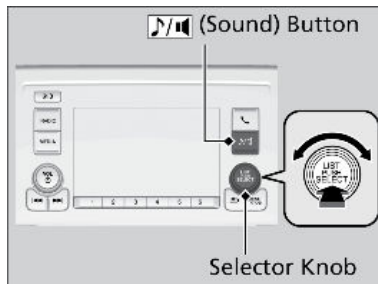

**Models with Display Audio**

Touch items on the screen to make and enter selections.

1. From the HOME screen, select an audio source.
2. Select Sound.
3. Select an item to change and adjust the setting.



**Color Audio System**

Use the buttons to control the display audio system.

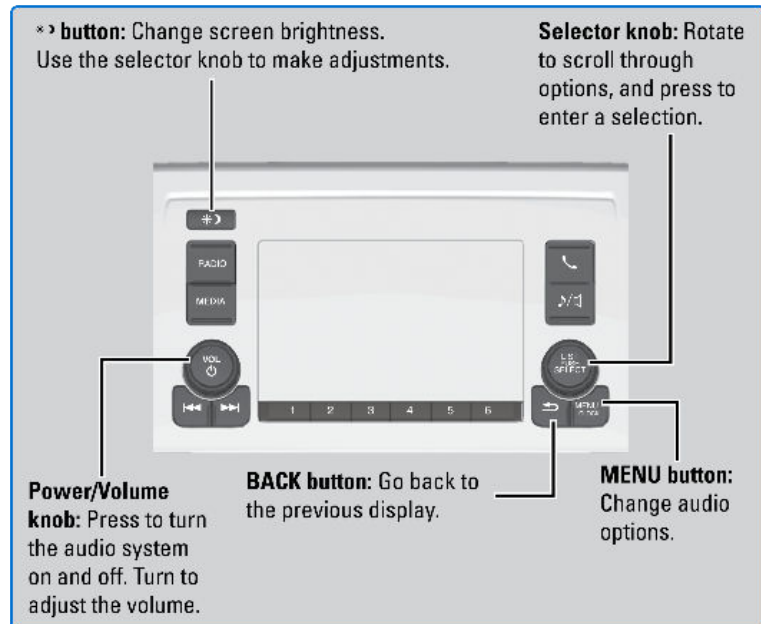

**Display Audio System**

Use simple gestures-including touching, swiping and scrolling-to operate certain audio functions.

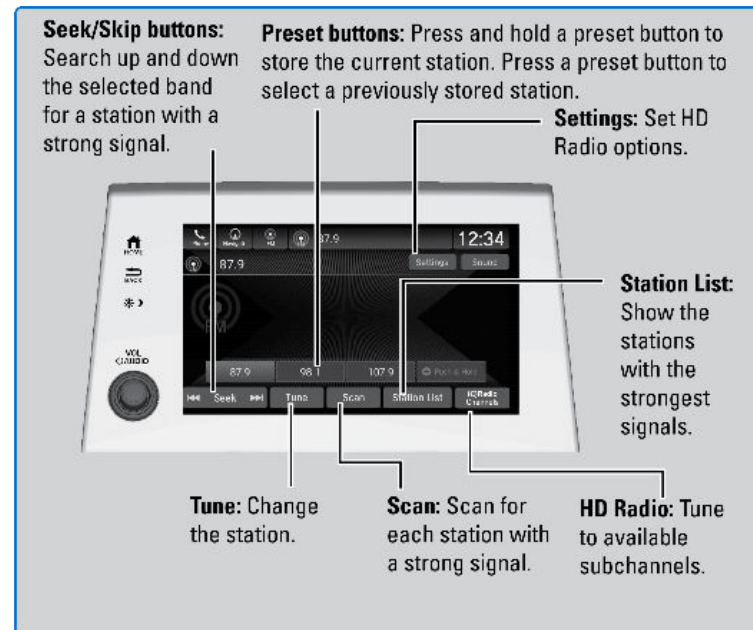

Some items may be grayed out during driving to reduce the potential for distraction. You can select them when the vehicle is stopped or use voice commands.

Wearing gloves may limit or prevent touchscreen response.

**HondaLink®**

**Models with Display Audio**

A subscription-based service that provides convenient features such as voice communication in case of emergency, online security, and one-on-one operator assistance \*1.

To check phone compatibility and get more information, visit [handsfreelink.com](http://handsfreelink.com) (US) or [handsfreelink.ca](http://handsfreelink.ca) (Canada). Standard data rates may apply with your phone service provider.

■ **HondaLink Menu**

Select a menu option.

\*1 - If equipped

**Vehicle:** Get instructional messages when your vehicle needs service.

**Messages from Honda:** Displays helpful and important information from Honda.

**Help & Support:** Displays tips for vehicle usage, get roadside assistance, or contact customer service.



■ **HondaLink Connection**

Follow the steps below to connect to HondaLink and use its features.

1. Download the HondaLink Connect app to your compatible smartphone.
2. Pair your phone to *Bluetooth HandsFreeLink* (see Pairing a Phone).
3. From the HOME screen, select HondaLink.
4. Certain features require you to send vehicle information to Honda. Select Enable Once, Always Enable, or Disable.

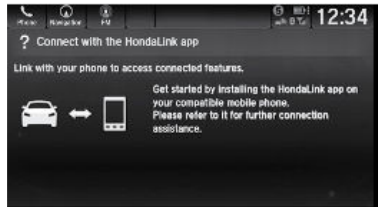

**HondaLink® Assist\*1**

If your vehicle’s airbags deploy or if the unit detects that the vehicle is severely impacted, your vehicle automatically attempts to connect to an operator. Your phone must be paired to the system and have good cellular connection. Visit [www.hondalink.com](http://www.hondalink.com) (U.S.) or [honda.ca/hondalinkassist](http://honda.ca/hondalinkassist) (Canada) for more information.

**Apple CarPlay™**

**Models with Display Audio**

Connect an Apple CarPlay-compatible iPhone to the system. You can use the touchscreen to make a phone call, listen to music, and more. Visit the Apple CarPlay website for more information. Park in a safe place before connecting your iPhone and launching any compatible apps.

\*1 - If equipped

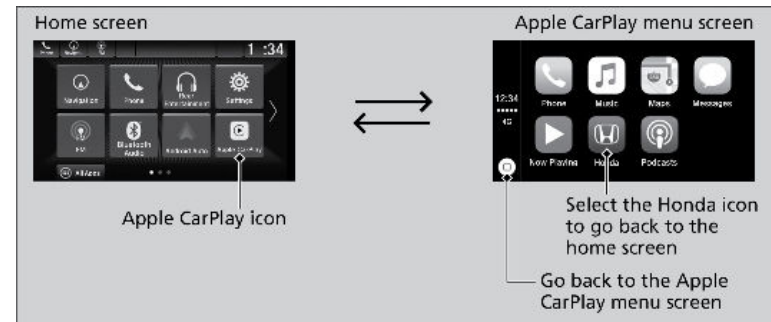

1. Connect the phone to the front (right side\*1) USB port. Compatible Android phones will prompt you to download any required apps.
2. Select Enable or Disable.
3. Follow any prompts shown on your phone.
4. The phone will be automatically paired. A tutorial will appear on the vehicle screen.
5. Select a menu option.
  - **Maps:** View a map and operate navigation. You can only use Apple Maps or the pre-installed navigation system to set a destination with routing guidance.
  - **Messages:** View and reply to text messages, or have messages read to you aloud by the system.

Once connected, press and hold the Talk button on the steering wheel (see Steering Wheel Controls) to operate the system using voice commands with Siri.

\*1 - If equipped  
 Depending on use, Apple CarPlay can share certain vehicle information (e.g., vehicle location, speed, and other operating conditions) with the connected iPhone. See Apple’s privacy policy for details regarding Apple’s use and handling of data uploaded by CarPlay. Use of CarPlay is at user’s own risk, and is subject to agreement to the CarPlay terms of use, which are included as part of the Apple iOS terms of use. CarPlay vehicle integration is provided “as is,” and Honda cannot guarantee CarPlay operability or functionality now or in the future due to, among other conditions, changes in CarPlay software/Apple iOS, service interruptions, or incompatibility or obsolescence of vehicle-integrated hardware or software. See dealer for details. Only use CarPlay when conditions allow you to do so safely. See your Owner’s Manual at [owners.honda.com](http://owners.honda.com) (U.S.) or [myhonda.ca](http://myhonda.ca) (Canada) for further license and warranty terms.

## Android Auto™

### Models with Display Audio

Connect a compatible Android phone to the system. You can use the touchscreen to make a phone call, listen to music, and more. Visit the Android Auto website for more information.

Park in a safe place before connecting your Android smartphone and launching any compatible apps.

1. Connect the phone to the front (right side\*1) USB port. Compatible Android phones will prompt you to download any required apps.
2. Select Enable or Disable.
3. Follow any prompts shown on your phone.
4. The phone will be automatically paired. A tutorial will appear on the vehicle screen.
5. Select a menu option.

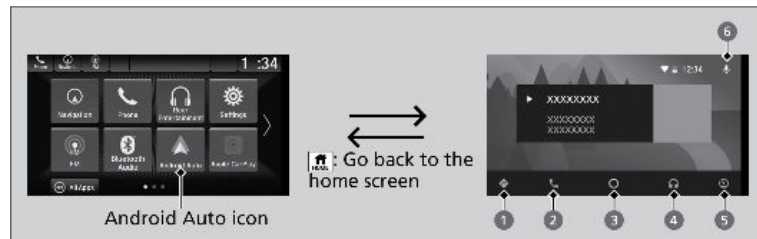

1. **Maps (Navigation):** View Google Maps and operate navigation. You can only use this system or the pre-installed navigation system to set a destination with routing guidance. You cannot enter destinations using the keyboard while the vehicle is moving.
2. **Phone:** Make phone calls or listen to voicemail.
3. **Home (Google Now):** Display useful information organized by Android Auto into simple cards that appear only when needed.
4. **Music:** Play music from compatible apps. Select this icon to switch between music apps.
5. **Return to HOME screen:** Displays a menu with an option to return to the vehicle system HOME screen.
6. **Voice:** Use voice commands via Google Voice Search to operate Android Auto. You can also press and hold the Talk button on the steering wheel (see Steering Wheel Controls) to say voice commands.

\*1 - If equipped

## Wi-Fi Connection

### Models with Display Audio

You can connect the audio system to the internet using Wi-Fi. If your compatible phone has hotspot capabilities, the system can be tethered to the phone. Follow the steps below to set up Wi-Fi when the vehicle is stopped. Standard data rates apply with your phone service provider.

1. From Home, select Settings.
2. Select Connections, then Wi-Fi.
3. Select Change Mode.
4. Select Network, then Save.
5. Select Connect.

Enter a password for the access point, and select OK.



## System Updates

### Models with Display Audio

Install authorized updates to the Display Audio system software. Install via a WiFi connection, WiFi connection or a USB storage device.

#### ■ Wireless Connection Setup

These steps are required only for updating via Wi-Fi.

*Depending on use, Android Auto can share certain vehicle information (e.g., vehicle location, speed, and other operating conditions) with Google and its service providers. See Google privacy policy for details regarding Google's use and handling of data uploaded by Android Auto. Use of Android Auto is at user's own risk, and is subject to agreement to the Android Auto terms of use, which are presented to the user when the Android Auto application is downloaded to the user's Android phone. Android Auto vehicle integration is provided "as is," and Honda cannot guarantee Android Auto operability or functionality now or in the future due to, among other conditions, changes in Android Auto software/Android operating system, service interruptions, or incompatibility or obsolescence of vehicle-integrated hardware or software. See dealer for details. Only use Android Auto when conditions allow you to do so safely. See your Owner's Manual at owners.honda.com (U.S.) or myhonda.ca (Canada) for further license and warranty terms.*

1. From the Home screen, select System Updates, then Settings.
2. Select Connection Setup.
3. Select Change Mode.
4. Select Network, then Save.  
The display returns to the network list.
5. Select an access point from the network list, then Connect.



**Wireless Updating**

1. From the Home screen, select System Updates.
2. Select Settings.
3. Select Connection Setup.
4. Select Change Mode.
5. Select Network, then Save.
6. Select an access point from the network list, then Connect.



**USB Updating**

Download the update

1. From the Home screen, select System Updates, then via USB.
2. Connect a flash drive to the front (right side\*1) USB port (see USB Port).
3. Once the system finishes copying to the flash drive, disconnect the drive and connect it to your computer.



\*1 - If equipped

4. Follow the link to download the updated files. See [usb.honda.com](https://usb.honda.com) for more details.

**Install the update**

1. From the Home screen, select System Updates, then via USB.
2. Connect the USB device containing the updated files to the front (right side\*1) USB port.
3. Select Install Now or Install While Vehicle Off.

**Note:**

- Honda recommends using a flash drive with 8GB capacity or higher.

Notes for wireless and USB updating:

- If you select Install Now, the system will reboot. Do not operate the Display Audio unit during the software update. You will see a notice when the update is complete.
- If you select Install While Vehicle Off, you will see a notice when the update is complete when you start the vehicle.

**FM/AM Radio**

Play FM or AM radio stations.

**Models with Color Audio**

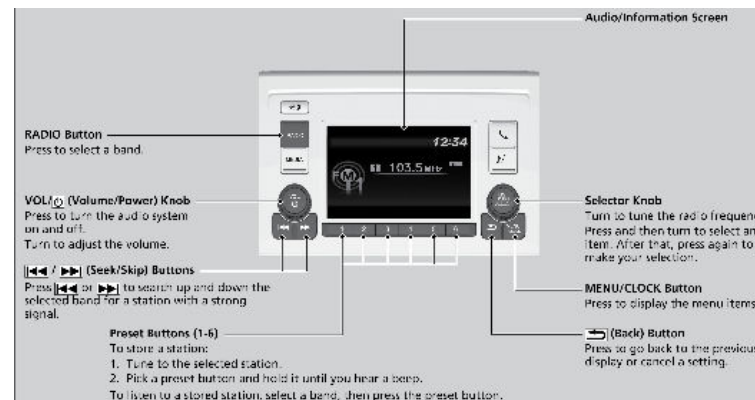

**Models with Display Audio**

\*1 - If equipped

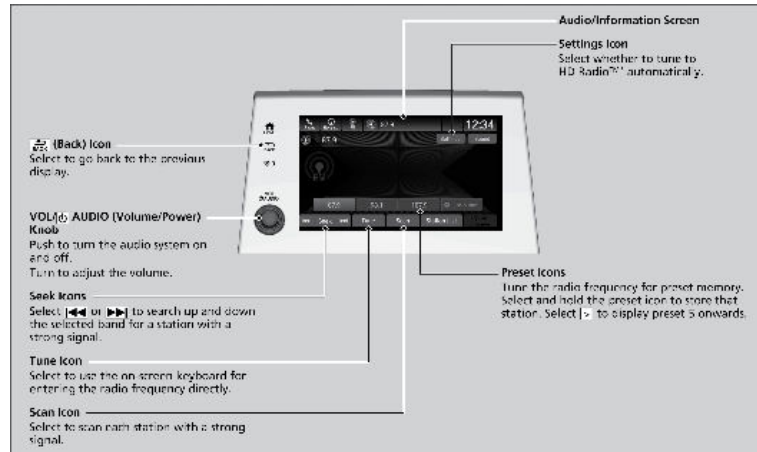

**SiriusXM® \*1**

**Models with Display Audio**

Available on a subscription basis only. For more information or to subscribe, contact your dealer, or visit [www.sirius.com/subscribe-now](http://www.sirius.com/subscribe-now) (U.S.) or [www.sirius.ca/subscribe-now](http://www.sirius.ca/subscribe-now) (Canada).

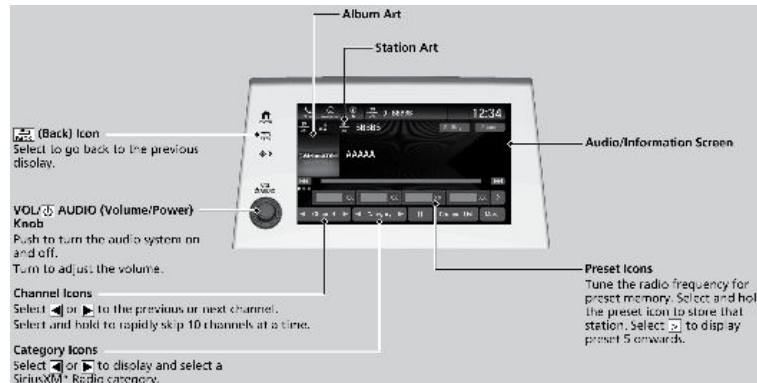

To learn about additional features—such as multi-channel preset, replay, or SportsFlash—see your Owner's Manual at [owners.honda.com](http://owners.honda.com) (U.S.) or [myhonda.ca](http://myhonda.ca) (Canada).

**iPod®**

Play and operate an iPod®\*14 through the vehicle's audio system. Connect your device to the USB port (see USB Port).

\*1 - If equipped

**Models with Color Audio**

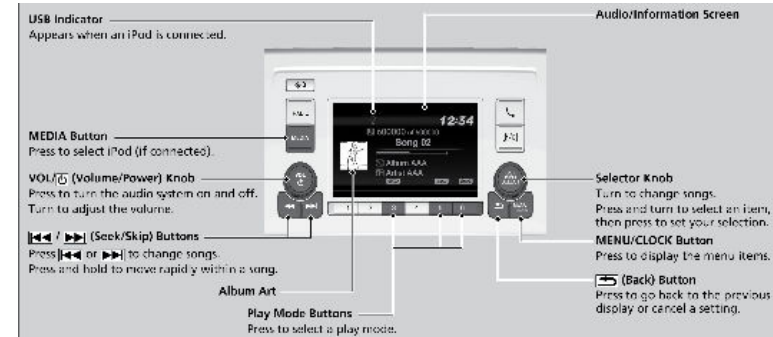

**Models with Display Audio**

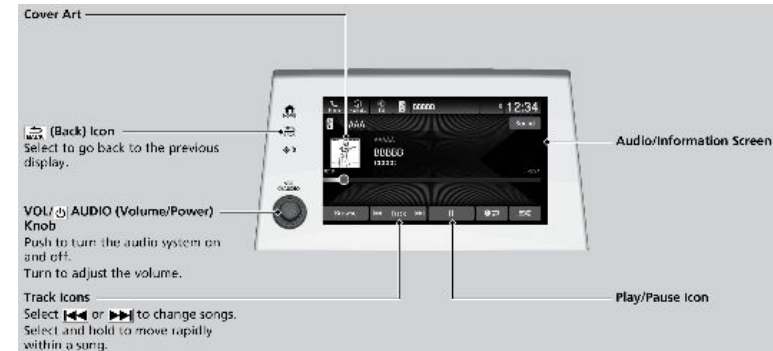

■ **Searching for Music**

**Models with Color Audio**

Use the selector knob to search for tracks stored on the iPod.

1. Press the selector knob to display the iPod music list.
2. Rotate the selector knob to select a category.
3. Press the selector knob to display a list of items in the category.

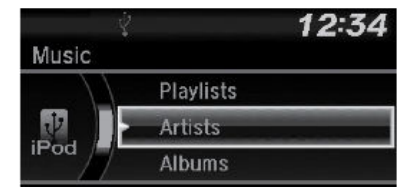

\*14 - iPod and iPhone are trademarks of Apple, Inc.

4. Rotate the selector knob to select an item, then press the selector knob. Press the selector knob and rotate it repeatedly until a desired item you want to listen to is displayed.

**Models with Display Audio**

Use the touchscreen to search for tracks stored on the iPod.

1. Select Browse.
2. Select the items on that menu.

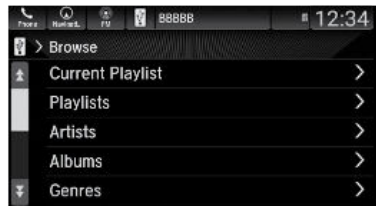

**USB Flash Drive**

Play and operate a USB flash drive through the vehicle's audio system. Connect your device (see USB Port).

**Models with Color Audio**

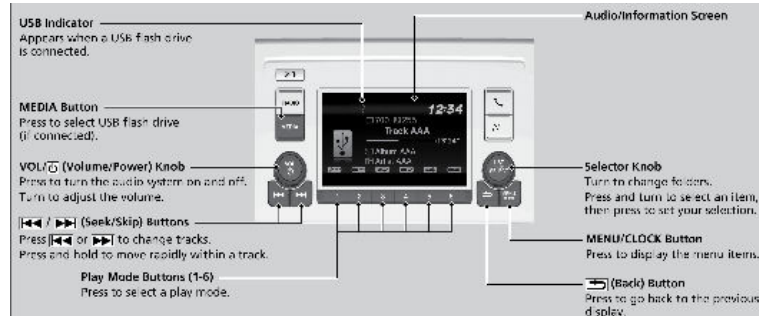

**Models with Display Audio**



**Searching for Music**

**Models with Color Audio**

Use the selector knob to search for tracks stored on the flash drive.

1. From the audio screen, press the selector knob.
2. Select a folder.
3. Select the track you want to play.



**Models with Display Audio**

Use the touchscreen to search for tracks.

1. Press the selector knob to display a folder list.
2. Rotate the selector knob to select a folder.
3. Press the selector knob to display a list of tracks in that folder.
4. Rotate the selector knob to select a track, then press the selector knob.

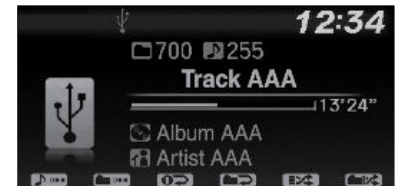

**Bluetooth® Audio**

Play streaming or stored audio from your compatible phone when it is paired to *Bluetooth® HandsFreeLink®* (see Pairing a Phone). Visit [handsfreelink.com](http://handsfreelink.com) (US) or [handsfreelink.ca](http://handsfreelink.ca) (Canada) to check phone compatibility. Standard data rates apply with your phone service provider.

**Models with Color Audio**

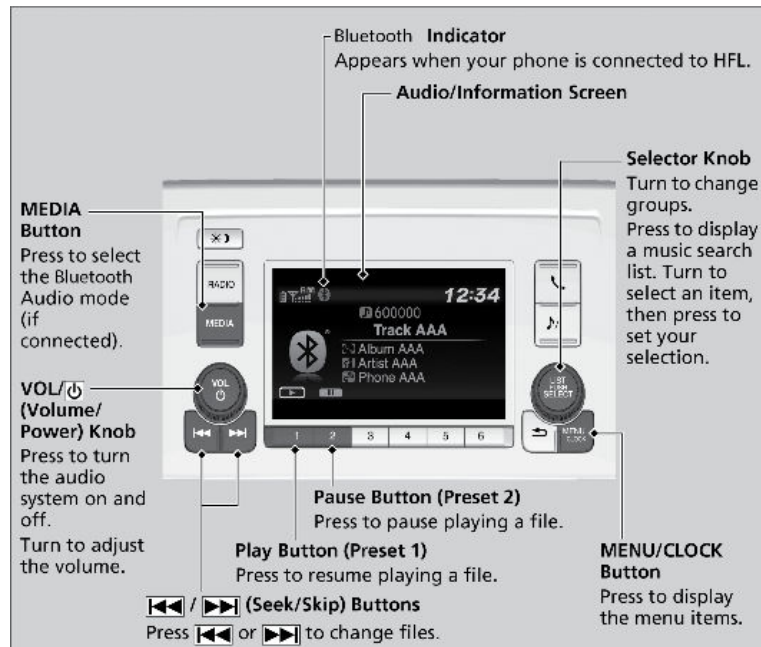

Models with Display Audio

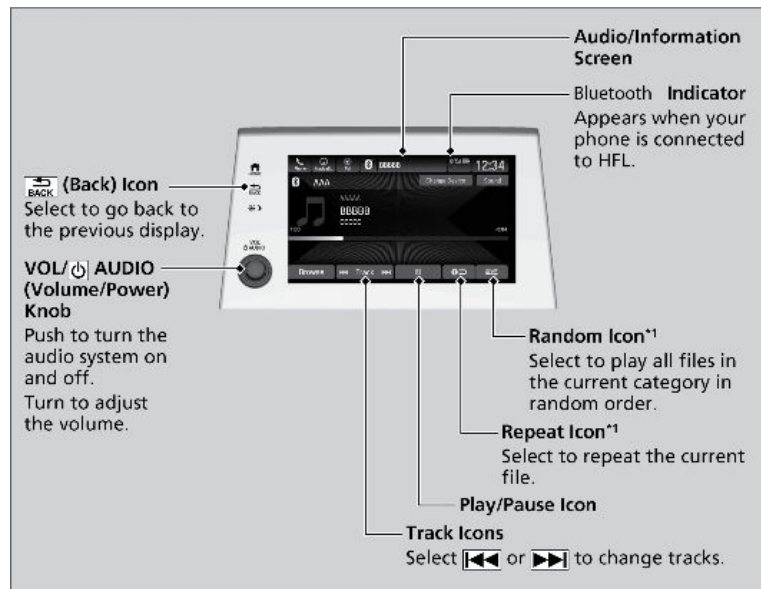

■ Searching for Music

Models with Color Audio

Use the selector knob to search for tracks stored on the device.

1. From the audio screen, press the Selector Knob.
2. Select a category to display a list of items.
3. Select the track you want to play.

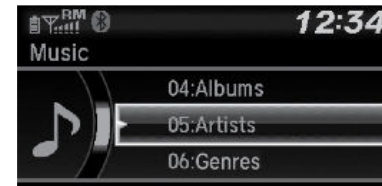

Models with Display Audio

1. Select Browse.
2. Select a search category (e.g., Albums).
3. Select an item.

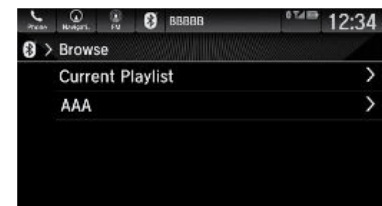

Note:

- Make sure the volume on your phone is properly adjusted.
- You may need to enable additional settings on your phone for playback.
- The resume/pause function and remote audio controls are not supported on all phones.

Compact Disc (CD)\*1 Player

The audio system supports audio CDs, CD-Rs, and CD RWs in MP3, WMA, or AAC formats. Insert a CD to begin automatic playback.

*Applicable laws may prohibit the operation of handheld electronic devices while operating a vehicle. Launch streaming audio on your phone only when safe to do so.*

*\*1 - If equipped*

Models with Display Audio

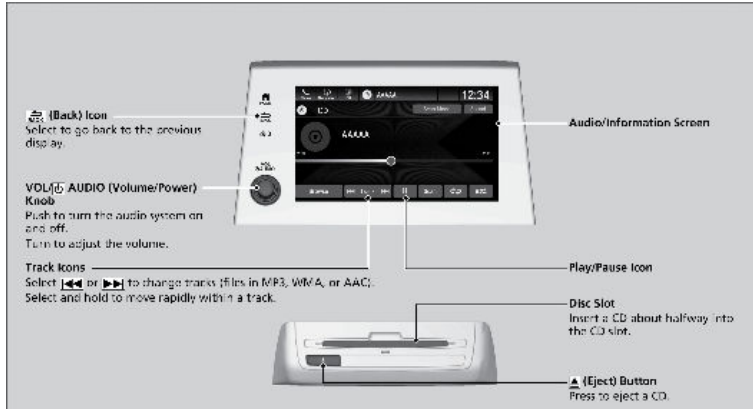

# BLUETOOTH® HANDSFREELINK®

Learn how to operate the vehicle's hands-free calling system.

## Basic HFL Operation

Make and receive phone calls using the vehicle's audio system, without handling your phone. Visit [automobiles.honda.com/handsfreelink/\(U.S.\)](http://automobiles.honda.com/handsfreelink/(U.S.)) or phone (888) 528-7876 (Canada) to check phone compatibility.

To reduce the potential for driver distraction, certain manual functions may be inoperable or grayed out while the vehicle is moving. Voice commands are always available.

### ■ HFL Displays and Controls

Use the controls to enter information and make selections.

#### Models with Color Audio

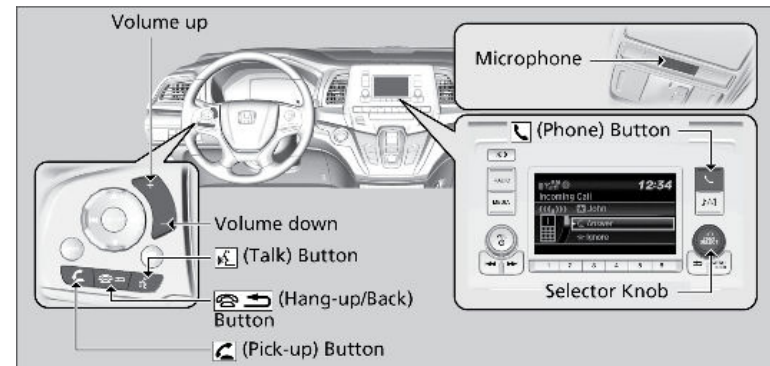



Models with Display Audio

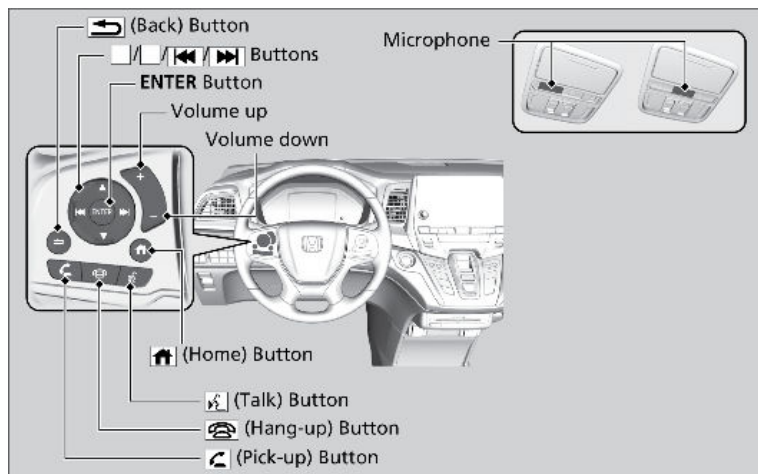

■ Talk Button Tips

When using the Talk button, wait for the beep before saying a command. The system recognizes only the commands listed in the Voice Command Index.

- When using the Talk button, wait until you hear a beep before speaking.
- To bypass the system prompts, simply press the Talk button again to say your command.\*1
- When the Talk button is pressed, all available voice commands are highlighted in yellow.\*1
- Speak in a clear, natural voice.
- Reduce all background noise.
- Adjust the dashboard vents away from the microphone on the ceiling.
- Close the windows and moonroof.

Pairing a Phone

To use hands-free phone and streaming audio functions, you must first pair your phone to the system. This can only be done when the vehicle is stopped. If there is an active connection to Apple CarPlay (see Models with Display Audio - Apple CarPlay™) or Android Auto (see Android Auto™), pairing of additional Bluetooth-compatible devices is unavailable and Add Bluetooth Device is grayed out from the Bluetooth Device List screen.

\*1 - If equipped

To use hands-free phone and streaming audio functions, you must first pair your phone to the system. This can only be done when the vehicle is stopped.

■ Pairing the First Phone

Models with Color Audio

Use the selector knob to make and enter selections.

1. Press the call button.
2. Rotate the selector knob to select Yes, then press the selector knob.
3. Make sure your phone is in search or discoverable mode, then press the selector knob.
4. When your phone appears on the list, select it by pressing the selector knob.



If your phone does not appear, select Phone Not Found? and search for Bluetooth® devices using your phone. From your phone, select HandsFreeLink.

5. The system gives you a pairing code on the audio/information screen.



Confirm if the pairing code on the screen and your phone match. This may vary by phone

6. A notification appears on the screen if pairing is successful.



Models with Display Audio

Use the touchscreen to make and enter selections.

Applicable laws may prohibit the operation of handheld electronic devices while operating a vehicle.

1. From the Home screen, select Phone.
2. Select Connect Phone.
3. Make sure your phone is in discovery mode, then select Connect New Device.
4. The system searches for your phone. Select your phone when it appears on the list.  
If your phone does not appear: search for HandsFreeLink from your phone. Connect to HFL.
5. The system gives you a pairing code. Compare it to the code that appears on your phone. Connect to HFL from your phone.
6. Select your desired options, then select Connect.

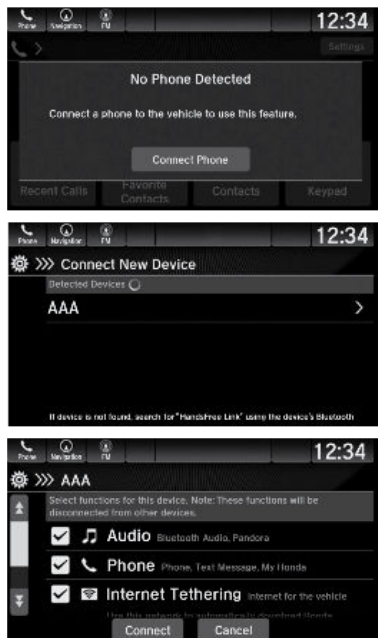

## Making a Call

You can make calls using several methods.

### ■ Dialing a Number

#### Models with Color Audio

Enter a 10-digit phone number to call. Use the selector knob to make and enter selections. This method is inoperable while the vehicle is moving.

1. Press the Phone button.
2. Select Dial.
3. Enter the phone number. Select the green phone icon to call.



#### Models with Display Audio

Enter a 10-digit phone number to call.

*Applicable laws may prohibit the operation of handheld electronic devices while operating a vehicle.*

1. From the Home screen, select Phone.
2. Select Keypad.
3. Enter the phone number.
4. Select Call.

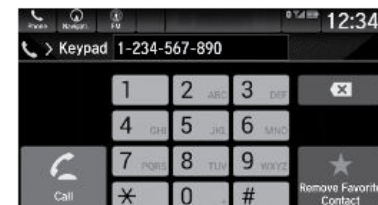

### ■ Using the Phonebook

When your phone is paired, its phonebook is automatically imported to the system. Use the selector knob to make and enter selections. This method is inoperable while the vehicle is moving.

#### Models with Color Audio

1. Press the Phone button.
2. Select Phonebook.
3. Scroll through the list to find the name and number you want to call, and select it to call.

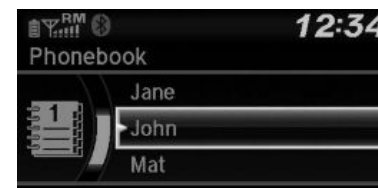

#### Models with Display Audio

When your phone is paired, its entire phonebook can be automatically imported to the system. Phone synchronization must be turned on.

1. From the Home screen, select Phone.
2. Select Contacts.
3. Scroll through the list to find the name.
4. Select a number.

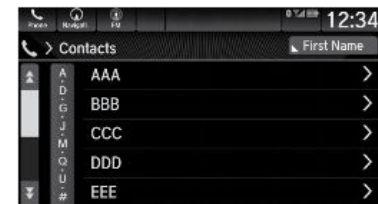

### ■ Storing Speed Dial Entries

#### Models with Color Audio

Up to 20 speed dial numbers can be stored per phone.

1. Press the phone button.
2. Rotate the selector knob to select Speed Dial, then press it.
3. Rotate the selector knob to select Add New, then press it.

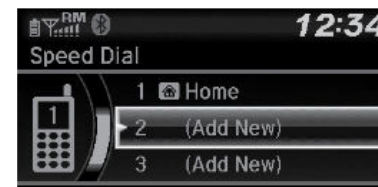

4. Rotate the selector knob to select a place to choose a number from, then press it.  
 From Call History:  
 Select a number from the call history.  
 From Phonebook:  
 Select a number from the connected cell phone's imported phonebook.  
 From Phone Number:  
 Input the number manually.
5. When the speed dial is successfully stored, you are asked to create a voice tag for the number. Rotate the selector knob to select Yes or No, then press it.
6. Using the talk button, follow the prompts to say the name for the speed dial entry.

■ Using Speed Dial

Models with Color Audio

Make calls quickly using stored speed dial entries or call history numbers. Use the selector knob to make and enter selections.

1. Press the Phone button.
2. Select Speed Dial.
3. Scroll through the list to find the entry you want to call, and select it to call.



Models with Display Audio

Make calls quickly using stored speed dial entries or call history numbers.

1. Go to the phone menu screen.
2. Select Favorite Contacts.  
 You can change the order of speed dial entries by selecting Reorder.
3. Select a number.

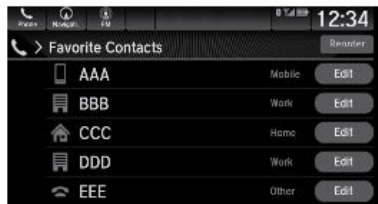

Siri™ Eyes Free

Activate Siri through your vehicle when an iPhone is paired to the system. Visit [handsfreelink.com](http://handsfreelink.com) (US) or [handsfreelink.ca](http://handsfreelink.ca) (Canada) to check phone compatibility.

Models with Display Audio

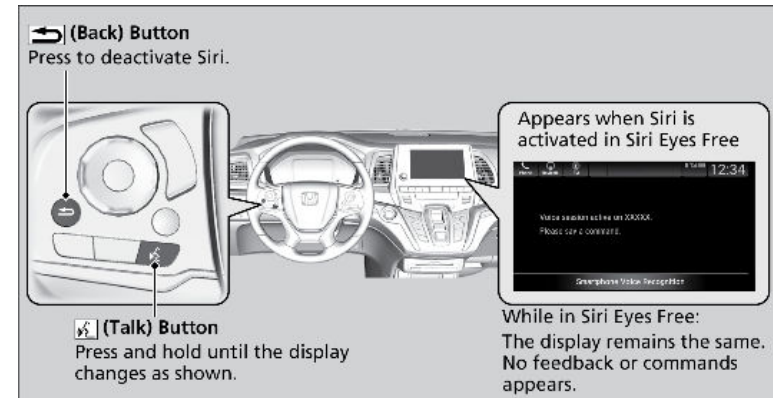

Here are some examples of Siri Commands:

- "Call John Smith"
- "Read my new text message"
- "Find a nearby sushi restaurant"
- "Remind me to pick up dinner"
- "Set up a meeting at 3 p.m."
- "Play song XYZ"

Note:

- Any requests that include visual feedback from Siri on your phone are not displayed in the vehicle.
- Certain commands rely on the iPhone's features and existing apps.
- To hear turn-by-turn directions or songs through the vehicle, set the audio source to *Bluetooth* Audio.

# NAVIGATION

Learn how to enter a destination and operate the navigation system\*1.

## Basic Navigation Operation

A real-time navigation uses GPS and a map database to show your current location and help guide you to a desired destination. You can operate the system using voice commands or the system controls.

**To reduce the potential of driver distraction, certain manual functions may be inoperable or grayed out while the vehicle is moving. Voice commands are always available.**

### Steering Wheel Controls

Use the steering wheel controls to give voice commands.

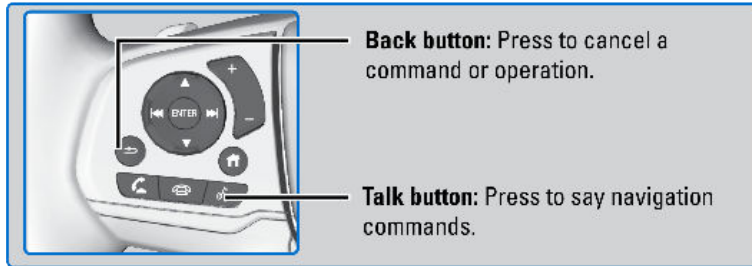

### Talk Button Tips

The system recognizes only the commands in the Voice Command Index, see Voice Portal Commands.

- When using the Talk button, wait for a beep before saying a command.
- To bypass the system prompts, simply press the Talk button again to say your command.
- Speak in a clear, natural voice.
- Reduce all background noise.
- Adjust the dashboard vents away from the microphone in the ceiling.
- Close the windows and moonroof\*1.

### System Guidance Volume

1. From the Home Screen, select Navigation.
2. Select Map Tools, Then Guidance volume.
3. Select + or - to adjust volume, or select Mute.
4. Press Back to exit the menus.



### Navigation Display and Controls

Touch icons on the screen to enter information and make selections.

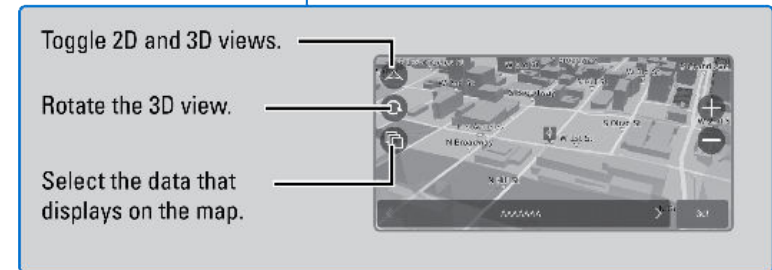
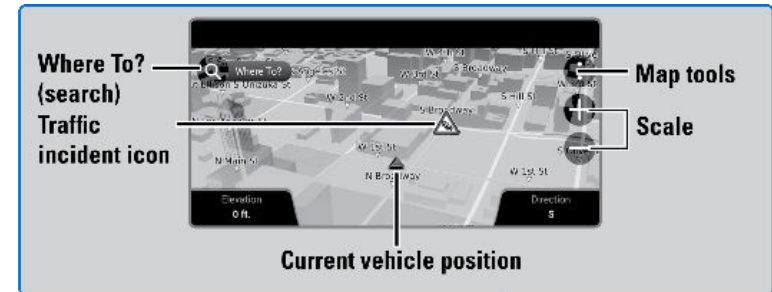

### Entering Your Destination

Use several methods to enter a destination.

#### Home Address

Store your home address in the system so you can easily route to it.

\*1 - If equipped

1. Select Set Home Location.
2. Select an option.

Select Use Current Location to set home location.

If selecting Enter My Address, Recently Found or Saved Place, proceed to steps 3 and 4.

3. Select the home location.
4. Select Select.

When your home address is stored, you can press the Talk button and say "Navigation" and then "Go Home" at any time. You can also select Go home from the Where To? menu.

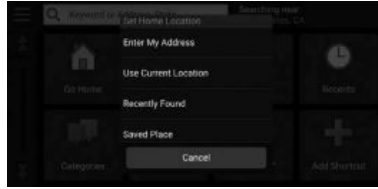

■ **Street Address**

Enter a street address.

1. From the map screen, select the Search icon.
2. Select Search Tools.
3. Select Address.
4. Enter the house number and street name.
5. Select Done or a suggestion.
6. Select the address from the list.
7. Select Go!.



■ **Place Category**

Enter a destination using a point of interest or landmark.

1. From the map screen, select the Search icon.
2. Select a Category.
3. Select a subcategory.

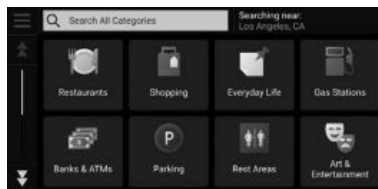

4. Select a place from the list.
5. Select Go!.

You can also enter a street address using voice commands. Press the Talk button and say "Navigation" and then "Find Place." Follow the prompts.

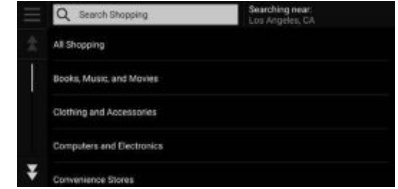

■ **Recent Places**

Select an address from a list of your 50 most recent destinations.

1. From the map screen, select the Search icon.
2. Select Recent.
3. Select a place from the list.
4. Select Go!.



■ **Saved Places**

Save locations so you can quickly route to them.

**Saving a Location**

1. Select a destination from the map.
2. Select the destination name at the bottom of the map.
3. Select Save.
4. Enter the address or place name and select done.



**Routing to a Saved Location**

1. Select a search method.  
Find a location that you want to save.

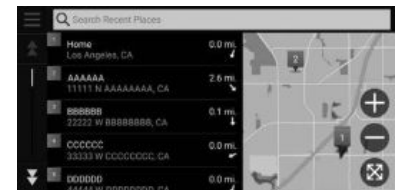

2. Select Info.
3. Select Save.
4. Enter a name and select Done.

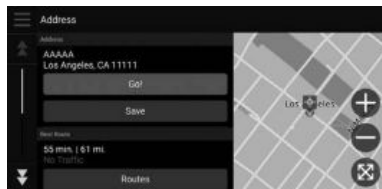

### Routing

After a destination is set, you can alter or cancel your route.

#### ■ Map Legend

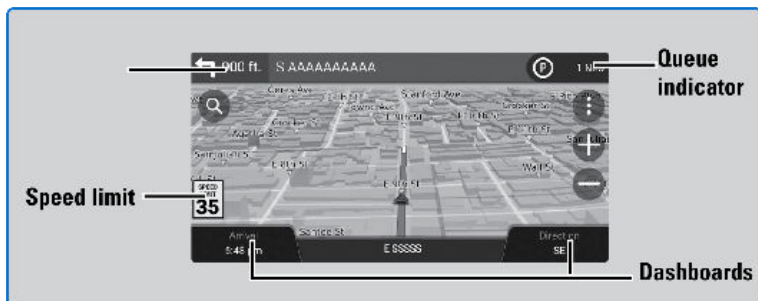

### ⚠ WARNING

Using the navigation system while driving can take your attention away from the road, causing a crash in which you could be seriously injured or killed.

Operate system controls only when the conditions permit you to safely do so.

## DRIVING

Learn about preparation for driving, as well as other features.

### Before Driving

Check the following items before you begin driving.

#### ■ Exterior Checks

- Make sure there are no obstructions on the windows, door mirrors, exterior lights, or other parts of the vehicle.
- Remove any frost, snow, or ice.
- Make sure the hood is securely closed.
- Heat from the engine and exhaust can ignite flammable materials left under the hood, causing a fire. If you've parked your vehicle for an extended period, inspect and remove any debris that may have collected, such as dried grass and leaves that have fallen or have been carried in for use as a nest by a small animal. Also check under the hood for leftover flammable materials after you or someone else has performed maintenance on your vehicle.
- Make sure the tires are in good condition.
- Make sure there are no people or objects behind or around the vehicle.

### NOTICE

If the doors are frozen shut, use warm water around the door edges to melt any ice. Do not try to force them open, as this can damage the rubber trim around the doors. When done, wipe dry to avoid further freezing.

#### ■ Interior Checks

- Store or secure all items on board properly.
- Do not pile items higher than the seat height.
- Do not place anything in the front seat footwells. Make sure to secure the floor mats.
- If you have any animals on board, do not let them move freely in the vehicle.
- Securely close and lock all doors and the tailgate.
- Adjust your seating position, mirrors, and steering wheel properly.
- Make sure items placed on the floor behind the front seats cannot roll under the seats.

- Everyone in the vehicle must fasten their seat belt.
- Make sure that the indicators in the instrument panel come on when you start the vehicle, and go off soon after.

In addition:

- During the first 600 miles (1,000 km) of operation, avoid sudden acceleration or full throttle operation so as to not damage the engine or powertrain.
- Avoid hard braking for the first 200 miles (300 km). You should also follow this when the brake pads are replaced.

**⚠ WARNING**

Improper accessories or modifications can affect your vehicle’s handling, and stability, and performance, and cause a crash in which you can be seriously hurt or killed.

Follow all instructions in the vehicle owner’s manual regarding accessories and modifications.

**Maximum Load Limit**

Carrying too much cargo or improperly storing it can affect your vehicle’s handling, stability, stopping distance, and tires, and make it unsafe. See the Tire and Loading Information label on the driver’s doorjamb.

■ **Maximum Load For Your Vehicle**

The maximum load for your vehicle type is:

- Models with 7-passenger seating: 1,173 lbs (532 kg)
- Models with 8-passenger seating: 1,340 lbs (608 kg)

Label Example

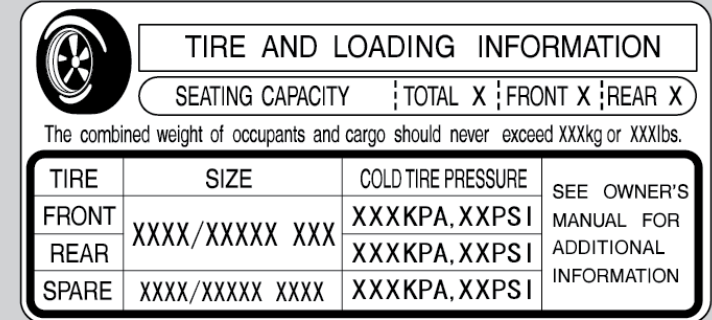

**⚠ WARNING**

Overloading or improper loading can affect handling and stability and cause a crash in which you can be hurt or killed.

Follow all load limits and other loading guidelines in this guide.

This figure includes the total weight of all occupants, cargo, and accessories, and the tongue load if you are towing a trailer. Below are the steps for determining the correct load limit:

1. Locate the statement “The combined weight of occupants and cargo should never exceed XXX kg or XXX lbs.” on your vehicle’s placard.
2. Determine the combined weight of the driver and passengers that will be riding in your vehicle.
3. Subtract the combined weight of the driver and passengers from XXX kg or XXX lbs.
4. The resulting figure equals the available amount of cargo and luggage load capacity. For example, if the “XXX” amount equals 1,400 lbs. (635 kg) and there will be five 150 lbs. passengers in your vehicle, the amount of available cargo and luggage load capacity is 650 lbs. (1,400 - 750 (5 x 150) = 650 lbs.).
5. Determine the combined weight of luggage and cargo being loaded on the vehicle. That weight may not safely exceed the available cargo and luggage load capacity calculated in step 4.
6. If your vehicle will be towing a trailer, load from your trailer will be transferred to your vehicle. Consult the Owner’s Manual to determine how this reduces the available cargo and luggage load capacity of your vehicle.

In addition, the total weight of the vehicle, all occupants, accessories, cargo, and trailer tongue load must not exceed the Gross Vehicle Weight Rating (GVWR) or the Gross Axle Weight Rating (GAWR). Both are on a label on the driver's doorjamb.

Load Limits Example

Example 1

Max Load  
1,340 lbs  
(608 kg)

Passenger Weight  
150 lbs x 2 = 300 lbs  
(68 kg x 2 = 136 kg)

Cargo Weight  
1,040 lbs  
(472 kg)

Example 2

Max Load  
1,340 lbs  
(608 kg)

Passenger Weight  
150 lbs x 5 = 750 lbs  
(68 kg x 5 = 340 kg)

Cargo Weight  
590 lbs  
(268 kg)

The headlight aim on your vehicle was set by the factory, and does not need to be adjusted. However, if you regularly carry heavy items in the trunk or tow a trailer, have the aiming readjusted at your dealer or by a qualified technician.

### Towing a Trailer

Your vehicle can tow a trailer if you carefully observe the load limits, use the proper equipment, and follow the towing guidelines. See the Owner's Manual at [www.owners.honda.com](http://www.owners.honda.com) (U.S.) or [myhonda.ca](http://myhonda.ca) (Canada) for more information.

#### Towing Load Limits

##### Total trailer weight

Do not exceed the maximum allowable weight of the trailer, cargo and everything in or on it shown in the table below. Towing loads in excess of this can seriously affect vehicle handling and performance and can damage the engine and drivetrain.

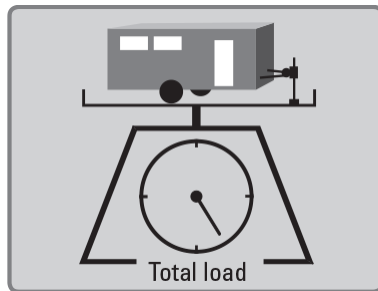

Passengers	LX, EX, EX-L	Touring, Elite
2	3,000 lbs (1,360 kg)	3,500 lbs (1,587 kg)
3	3,000 lbs (1,360 kg)	3,350 lbs (1,520 kg)
4	3,000 lbs (1,360 kg)	3,150 lbs (1,429 kg)
5	3,000 lbs (1,360 kg)	3,000 lbs (1,360 kg)
6	2,000 lbs (907 kg)	2,000 lbs (907 kg)
7	800 lbs (363 kg)	800 lbs (363 kg)
8	Not recommended	Not recommended

Each weight limit is calculated based on the following conditions:

- Occupants fill seats from the front of the vehicle to the back.
- Each occupant weighs 150 lbs (68 kg).
- Each occupant has 15 lbs (7 kg) of cargo in the cargo area.
- Any additional weight, cargo, or accessories reduce the maximum trailer weight and maximum tongue load.

##### Tongue Load

The weight of the tongue with a fully loaded trailer on the hitch should be approximately 10% of the total trailer weight.

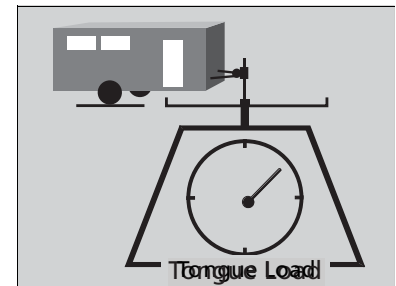

- Excessive tongue load reduces front tire traction and steering control. Too little tongue load can make the trailer unstable and cause it to sway.



- To achieve a proper tongue load, start by loading 60% of the load toward the front of the trailer and 40% toward the rear. Readjust the load as needed.

### ⚠ WARNING

Exceeding any load limit or improperly loading your vehicle and trailer can cause a crash in which you can be seriously hurt or killed.

Check the loading of your vehicle and trailer carefully before starting to drive.

#### Pre-tow Checklist

When preparing to tow, and before driving away, ensure the following:

- The vehicle has been properly serviced, and the suspension and the cooling system are in good operating condition.
- Avoid towing a trailer during your vehicle's first 600 miles (1,000 km).
- The trailer has been properly serviced and is in good condition.
- All weights and loads are within limits. Never exceed the gross weight ratings.
- Check if all loads are within limits at a public scale.
- The hitch, safety chains, and any other attachments are secure.
- All items in or on the trailer are properly secured and cannot shift while you drive.

### ⚠ WARNING

Exceeding any load limit or improperly loading your vehicle and trailer can cause a crash in which you can be seriously hurt or killed.

Check the loading of your vehicle and trailer carefully before starting to drive.

## Towing Behind A Motorhome

Your vehicle is not designed to be towed behind a motorhome. If your vehicle needs to be towed in an emergency, refer to Emergency Towing.

Improper towing such as towing behind a motorhome or other motor vehicle can damage the transmission.

## Starting to Drive

Turn on the vehicle and start the engine to begin driving.

### ■ Before Starting the Engine

Check that the electric parking brake is applied and the transmission is in P. Keep your foot firmly on the brake pedal when starting the engine.

**Note:** The engine is harder to start in cold weather and in thinner air found at altitudes above 8,000 feet (2,400 m). When starting the engine in cold weather, turn off all electrical accessories such as the lights, climate control system, and rear defogger in order to reduce battery drain.

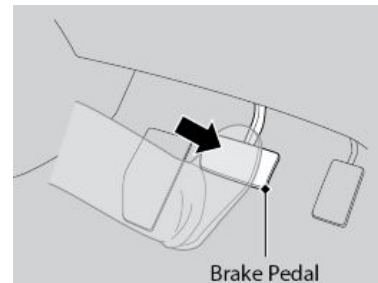
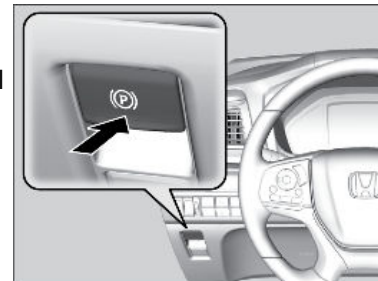

### ■ Changing the Power Mode\*1

Use the ENGINE START/STOP button to cycle through power modes or start the engine.

**Accessory or On mode:** Press the ENGINE START/STOP button once without pressing the brake pedal for Accessory mode. Press it again for On mode.

**Starting the engine:** Press and hold the brake pedal or clutch, then press the ENGINE START/STOP button. Keep your foot firmly on the brake pedal when starting the engine. If you press the button and the shift lever is not in Park (P), the vehicle goes into Accessory mode.

**Turning the vehicle off:** Shift to Park (P), apply the parking brake, then press the ENGINE START/STOP button.

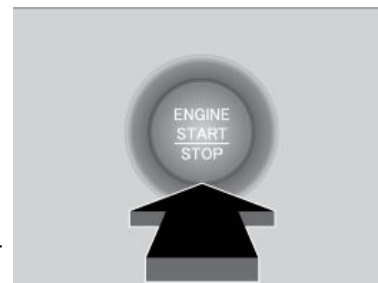

## Shifting

Change the shift position based on your driving needs.

### ■ Electronic Gear Selector\*1

Select the vehicle's gear using a simple button interface. Apply the brake pedal and select a gear.

**Park (P):** Used for parking or starting. Press P with the brake pedal pressed. A red indicator appears.

**Reverse (R):** Pull back the (R) button to put the vehicle in Reverse.

**Neutral (N):** Press the (N) button to put the vehicle in Neutral.

**Drive /S Position(D/S):** Used for normal driving (D) or driving in Sport mode (S). Press D/S once for normal driving. Press D/S twice for Sport mode driving. A green indicator appears. Make sure the electric parking brake is released.



#### ⚠ WARNING

The vehicle can roll away if left unattended without confirming that Park (P) is engaged. Always keep your foot on the brake pedal until you have confirmed that (P) is shown on the gear position indicator.

#### NOTICE

When you change from D to R and vice versa, or want to change to Park (P), come to a complete stop and keep the brake pedal applied. Operating the gear buttons before the vehicle has come to a complete standstill can damage the transmission.

#### Auto park mode

For your convenience, Park (P) is automatically engaged when the vehicle is turned off, or when all of the following conditions are met: the vehicle is stopped with the engine running, the driver's seat belt is unbuckled, and the driver's door is opened. You should always apply the brake and shift to Park when idling, or before exiting the vehicle.

If you select any gear other than Park when the driver's door is opened and the driver's seat belt is unbuckled, Park is re-engaged when the brake pedal is released.

\*1 - If equipped

#### Car wash mode

Follow the procedure below to use a conveyor-style car wash where you or an attendant do not remain in the vehicle. Make sure the wiper lever is in the OFF position. You should inform the car wash attendant of this procedure.

1. When the engine is running, apply the brake pedal, select Neutral (N), then release the brake pedal.
2. Press and hold Neutral for two seconds. This puts the vehicle into car wash mode.

If the ENGINE START/STOP button is pressed while the vehicle is in car wash mode, the power mode will change to ACCESSORY and a message will be displayed on the driver information interface. After 15 minutes, the gear position changes to Park and the power mode changes to OFF.

#### ⚠ WARNING

When the transmission is too hot, car wash mode may not be available. Let the engine idle to cool the transmission.

### Auto Idle Stop\*1

To help maximize fuel economy, the engine automatically stops when the vehicle comes to a stop, depending on environmental and vehicle operating conditions. The indicator (green) comes on at this time.

#### ■ Activating Auto Idle Stop

When the vehicle stops with the gear position in Drive (D) and the brake pedal is pressed, the engine turns off and the auto idle stop indicator appears if conditions permit.

When you release the brake pedal, turn the steering wheel, or press the accelerator pedal, the engine restarts and the vehicle begins to move.

Auto idle stop may not activate (or the engine may automatically restart) when the vehicle is stopped by braking suddenly, the vehicle comes to a stop again before the vehicle speed reaches 3 mph (5 km/h) after the engine starts, the 12V battery is low, or when other conditions are met. For a complete list of conditions, see your Owner's Manual at [www.owners.honda.com](http://www.owners.honda.com) when the driver's seat belt is unfastened, the



\*1 - If equipped

vehicle is stopped on a steep hill, the windshield defroster is on, and other conditions..

#### ■ Turning the System On or Off

Press the Auto Idle Stop Off button to turn the system off. The amber auto idle stop indicator comes on. Press the button again to turn it on. The Auto Idle Stop system is turned on every time you start the engine, even if you turned it off the last time you drove the vehicle.

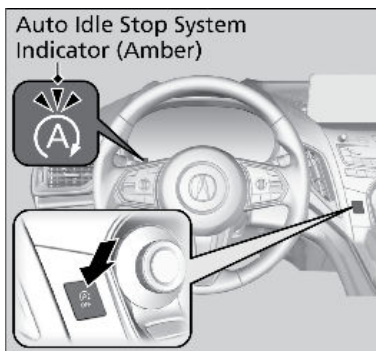

## Braking

Slow down or stop your vehicle, and keep it from moving when parked.

#### ■ Foot Brake

Press the brake pedal to slow down or stop your vehicle from moving.

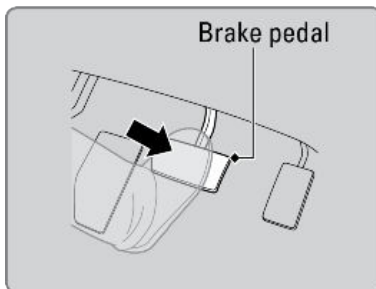

#### ■ Electric Parking Brake

Keep the vehicle from moving when it is parked.

**To apply:** Push the switch. The BRAKE indicator appears in the instrument panel. Push and hold the switch down for emergency braking while the vehicle is moving.

**To release:** Press the brake pedal and make sure your seat belt is fastened. Pull the switch up to release. Or, release by lightly pressing the accelerator pedal while the vehicle is in gear.

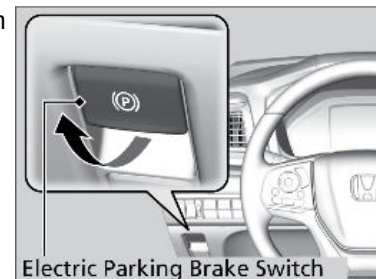
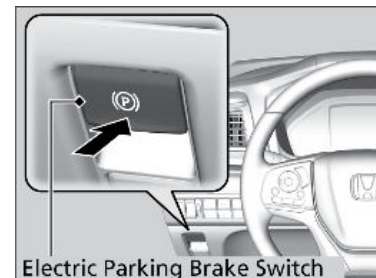

#### ■ Brake Assist System

During hard or emergency braking, the system increases braking force. The brake pedal may move slightly or make a noise; this is normal. Continue to hold the brake pedal firmly down.

#### ■ Anti-Lock Brake System (ABS)

During hard or emergency braking, the system rapidly pumps the brakes to prevent wheel lockup and help you maintain steering control. Do not pump the brake pedal, rather continue to hold it firmly down.

When ABS activates, you may notice vibrations through the brake pedal or the vehicle body, the brake pedal depressing further than usual, or hear a motor noise from the engine compartment. These are all normal.

### NOTICE

The ABS may not function correctly if you use an incorrect tire type and size.

## Intelligent Traction Management System

Optimizes vehicle performance to help you drive on snowy surfaces. The mode you select appears on the instrument display.

**Normal:** (Snow mode not selected) Provides balanced driving performance on most road surfaces.

**Snow:** Use when driving on snowy road surfaces.



### Vehicle Stability Assist® (VSA®) System

Also known as Electronic Stability Control (ESC), VSA helps to stabilize the vehicle during cornering if the vehicle turns more or less than what was intended. It assists in maintaining traction on slippery surfaces by regulating engine output and selectively applying the brakes.

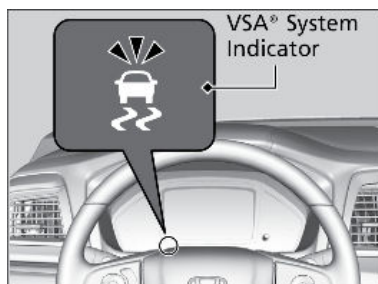

#### ■ Turning VSA On or Off

VSA is turned on every time you start the engine, even if you previously turned it off. If you turn VSA off, your vehicle has normal braking and cornering ability, but VSA traction and stability enhancement become less effective.

Press and hold the VSA OFF button until you hear a beep to turn VSA on or off.

The VSA OFF indicator appears when the system is off.

Traction control stops functioning, which may make it easier when trying to free your vehicle if it is stuck in mud or snow. Immediately after freeing your vehicle, be sure to switch VSA on again.

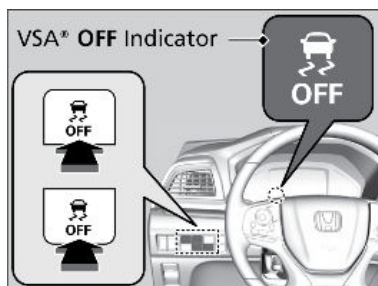

### Honda Sensing®

Honda Sensing® is a driver support system which employs the use of two distinctly different kinds of sensors, a radar sensor located in the front grille and a front sensor camera mounted to the interior side of the windshield, behind the rearview mirror.

These are the components of Honda Sensing®:

**Adaptive Cruise Control (ACC)\*1:** Helps maintain a constant vehicle speed and a set following interval behind a vehicle detected ahead of yours, without you having to keep your foot on the brake or the accelerator.

**Road Departure Mitigation (RDM) System:** Alerts and helps to assist you when the system detects a possibility of your vehicle unintentionally crossing over detected lane markings and/or leaving the roadway altogether.

**Lane Keeping Assist System (LKAS):**

Provides steering input to help keep the vehicle in the middle of a detected lane and provides tactile and visual alerts if the vehicle is detected drifting out of its lane.

**Collision Mitigation Braking System™ (CMBS™):** Can assist you when there is a possibility of your vehicle colliding with a vehicle or a pedestrian detected in front of yours. The CMBS™ is designed to alert you when a potential collision is determined, as well as to reduce your vehicle speed to help minimize collision severity when a collision is deemed unavoidable.

### Cruise Control\*1

Maintain a constant vehicle speed without having to keep your foot on the accelerator pedal. Use cruise control on freeways or open roads where you can travel at a constant speed with little acceleration or deceleration.

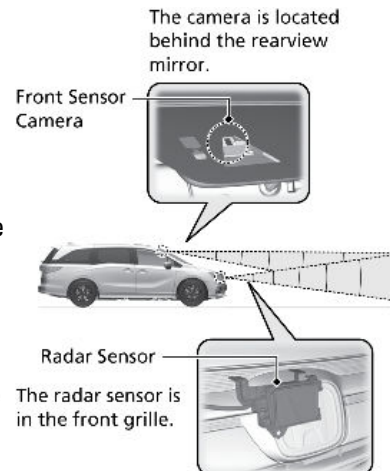

\*1 - If equipped

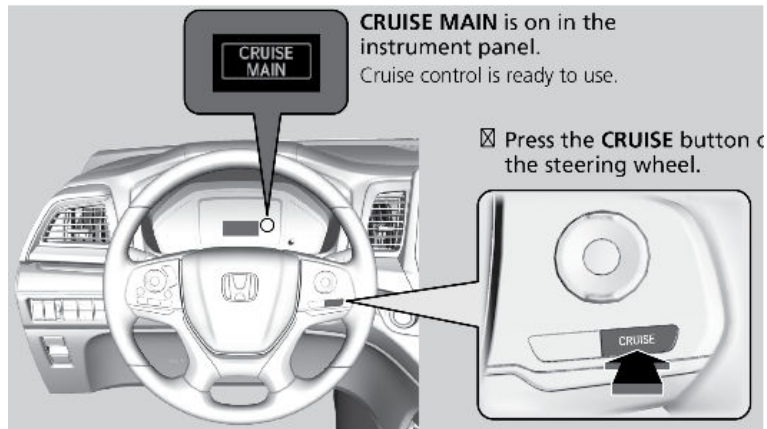

#### ■ Activating and Setting the Vehicle Speed

1. Press the CRUISE button. The CRUISE MAIN indicator appears.
2. Accelerate to the desired speed (above 25 mph/ 40 km/h). Take your foot off the pedal and press the -/SET button to set the speed. The CRUISE CONTROL indicator appears.

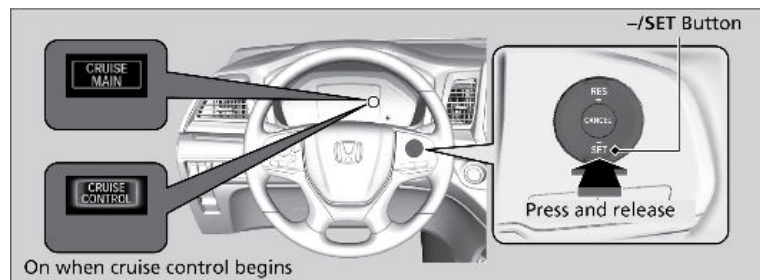

#### ■ Adjusting the Vehicle Speed

Press the RES/+ button to increase speed or the -/SET button to decrease speed.

Each time you press the button, the vehicle speed is increased or decreased by about 1 mph (1.6 km/h). If you keep the button pressed, the vehicle speed increases or decreases until you release it.

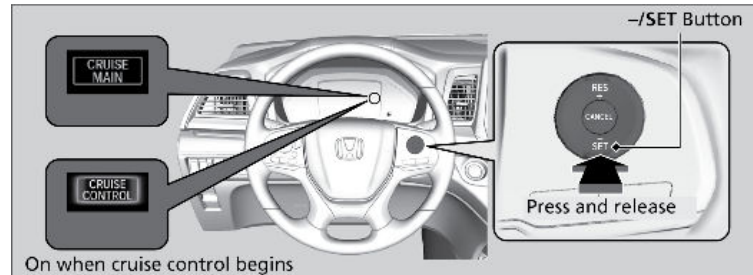

#### ■ Canceling Cruise Control

Press the CANCEL button, the MAIN button or the brake pedal. The CRUISE CONTROL indicator goes off.

After cruise control has been canceled, you can still resume the prior set speed by pressing the RES/+ button while driving at a speed of at least 25 mph (40 km/h).

Press CRUISE to turn the system off.



#### ⚠ WARNING

Improper use of cruise control can lead to a crash. Use cruise control only when traveling on open highways in good weather.

#### Adaptive Cruise Control (ACC)

Helps maintain a constant vehicle speed and a set following interval behind a vehicle detected ahead of yours.

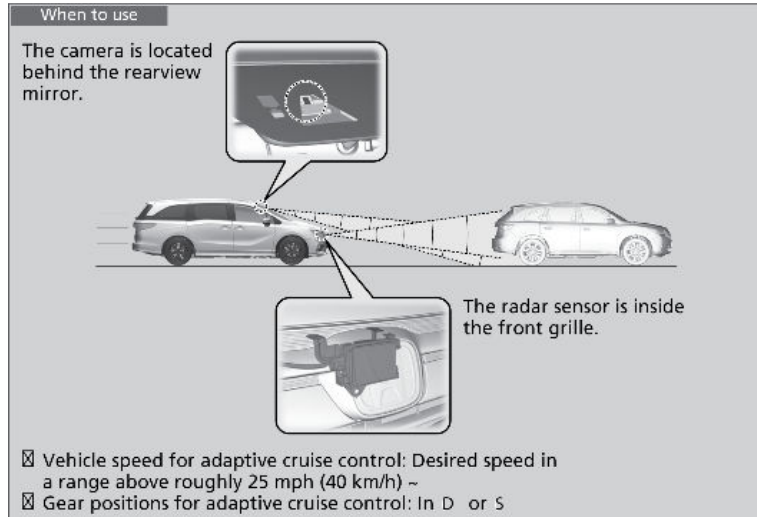

■ **Activating and Setting the Vehicle Speed**

1. Press the MAIN button. The ACC indicator appears in the multi-information display.
2. Accelerate to the desired speed (above 25 mph/40 km/h). Take your foot off the pedal and press the SET/- button to set the speed.

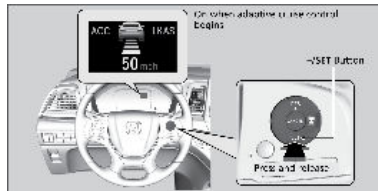

■ **Adjusting the Vehicle Speed**

Press the RES/+ button to increase speed or the SET/- button to decrease speed.



Each time you press the button, the vehicle speed is increased or decreased by about 1 mph (1.6 km/h). If you keep the button pressed, the vehicle speed increases or decreases by 5 mph or 5 km/h until you release it.

■ **Adjusting the Vehicle Distance**

Press the Interval button to change the following interval. Each time you press the button, the setting cycles through extra long, long, middle, and short.

■ **During Operation**

If a vehicle is detected ahead of you when ACC is turned on, the system maintains, accelerates, or decelerates your vehicle's set speed to keep the vehicle's set following interval from the vehicle ahead.

If a vehicle detected ahead of you slows down abruptly, or if another vehicle cuts in front of you, a beep sounds and BRAKE appears on the multi-information display to alert you .

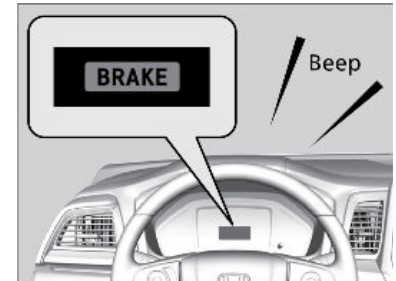

When your vehicle speed drops below 22 mph (35 km/h), ACC will cancel and no longer apply your vehicle's brakes. Always be ready to brake when needed.

**⚠ WARNING**

ACC has limited braking capability. When your vehicle speed drops below 22 mph (35 km/h), ACC will automatically cancel and no longer will apply your vehicle's brakes. Always be prepared to apply the brake pedal when conditions require.

■ **Canceling ACC**

Press the CANCEL button, MAIN button or press the brake pedal.

Certain conditions may cause ACC to cancel automatically. When this happens, a message appears on the multi-information display.

After cruise control has been canceled, you can still resume the prior set speed by pressing the RES/+ switch.

Press the MAIN button to turn the system off.

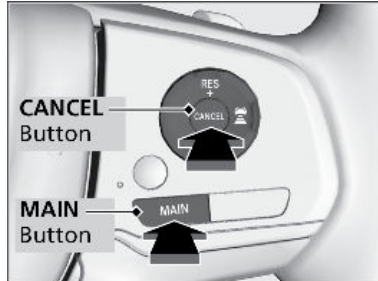

**⚠ WARNING**

Improper use of ACC can lead to a crash.  
Use ACC only when traveling on open highways in good weather.

■ **Switching to Standard Cruise Control**

Press and hold the Interval button.

Cruise Mode Selected appears in the multi-information display. Press and hold the button again to switch back to ACC.

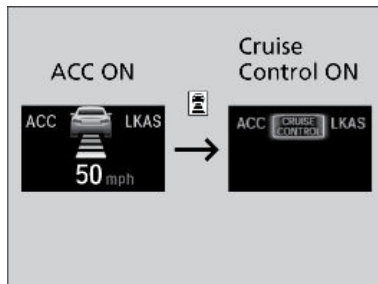

**Lane Keeping Assist System (LKAS)\*1**

A camera mounted between the windshield and the rearview mirror determines if your vehicle begins to move away from the center of a detected lane while driving between 45–90 mph (72–145 km/h).

If you cross a detected lane line without using your turn signal, a message appears on the DII and the steering vibrates slightly.

☒ **Steering input assist**

The system applies torque to the steering to keep the vehicle between the left and right lane lines. The applied torque becomes stronger as the vehicle gets closer to either of the lane lines.

☒ **Front sensor camera**  
Monitors the lane lines



☒ **Tactile and visual alerts**  
Rapid vibrations on the steering wheel and a warning display alert you that the vehicle is drifting out of a detected lane.

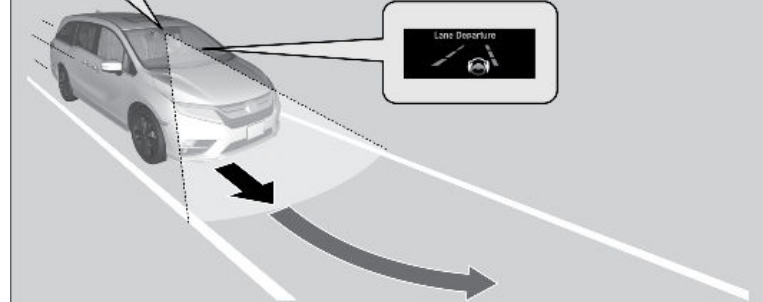

When you operate the turn signals to change lanes, the system is suspended, and resumes after the signals are off.  
If you make a lane change without operating the turn signals, the LKAS alerts activate, and torque is applied to the steering.

■ **Turning the System On or Off**

1. Press the MAIN button. LKAS appears in the MID.

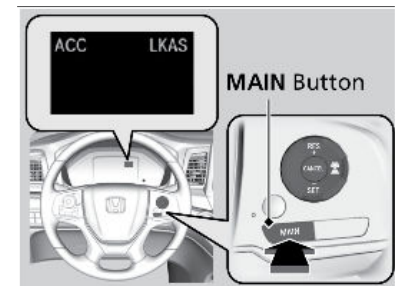

\*1 - If equipped

- Press the LKAS button. Lane outlines appear in the multi-information display. Dotted lane lines turn solid when the system activates.
- Press the MAIN button or the LKAS button to turn the system off.

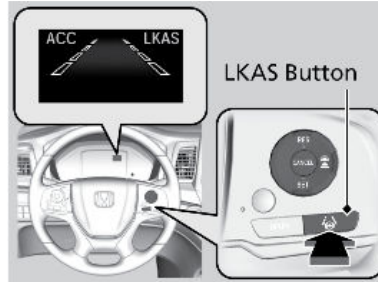

#### ■ Important Safety Reminder

LKAS is for your convenience only. It is not a substitute for your vehicle control. The system does not work if you take your hands off the steering wheel or fail to steer the vehicle.

Do not place an object on the top of the instrument panel. It may reflect onto the windshield and prevent the system from detecting lane lines properly.

#### Road Departure Mitigation (RDM)\*1

Alerts and helps to assist you if the system determines a possibility of your vehicle unintentionally crossing over detected lane markings while driving between 45-90 mph (72-145km/h).

Braking may also be applied if the lane lines are solid and continuous.

If the system operates several times without detecting driver response, the system beeps to alert you.

#### ■ Turning the System On or Off

Press the RDM button to turn the system on or off. A green indicator appears on the button when the system is on.

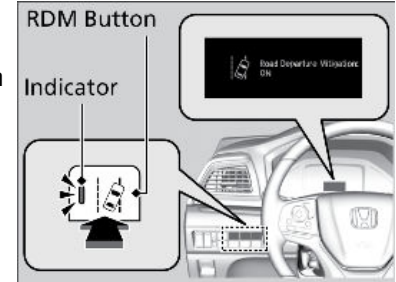

#### ■ Changing Settings

Determine the warning type.

- From the HOME screen, select Settings.
- Select Vehicle. The vehicle must be in Park (P).
- Select Driver Assist System Setup.
- Select Road Departure Mitigation Setting.
- Select from the options.
  - Normal (default): Steering control starts from inside the lane edge.
  - Wide: Steering control starts from outside the lane edge.
  - Warning Only: The system only provides a BRAKE message and steering wheel vibrations, but does not apply steering torque or braking.
- Press Save.



#### ■ Important Safety Reminder

The RDM system has limitations. Over-reliance on it may result in a collision. It is always your responsibility to keep your vehicle within the driving lane.

#### Collision Mitigation Braking System™ (CMBS™)\*1

Can assist you when there is a possibility of your vehicle colliding with a vehicle or a pedestrian detected in front of yours.

\*1 - If equipped

\*1 - If equipped



The system can give you visual, audible, and tactile alerts when a potential collision is determined, and reduce your vehicle speed to help minimize collision severity when a collision is deemed unavoidable.

When a potential collision with a detected oncoming vehicle is determined, the system also alerts you with rapid vibrations on the steering wheel.

The system activates when:

- The speed difference between your vehicle and a vehicle or pedestrian detected in front of you is about 3 mph (5 km/h) and over with a chance of a collision.
- Your vehicle speed is about 62 mph (100 km/h) or less and there is a chance of a collision with an oncoming detected vehicle or a pedestrian in front of you.

#### ■ Alert Stages

The system has three alert stages for a possible collision. Depending on the circumstances or CMBS™ settings, CMBS™ may not go through all of the stages before initiating the last stage.

**Stage 1:** Visual and audible warning.

**Stage 2:** Visual and audible warning, light brake application.

**Stage 3:** Visual and audible warning, strong brake application.

#### ■ Changing Settings

Determine the warning timing. The vehicle must be in Park (P).

1. From the HOME screen, select Settings.
2. Select Vehicle.
3. Select Driver Assist System Setup.
4. Select Forward Collision Warning Distance.
5. Select Long, Normal, or Short.
6. Press Save.

#### ■ Turning the System On or Off

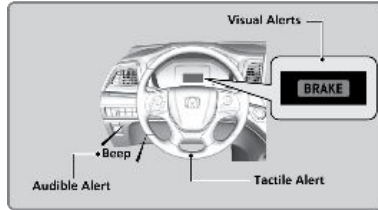

Press and hold the CMBS™ OFF button. A beep sounds and a message appears in the Driver Information Interface. The CMBS™ indicator appears when the system is off. CMBS™ automatically resets back to ON each time you start the engine.

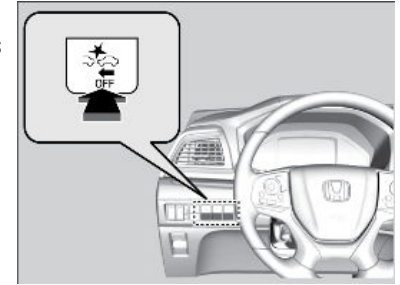

#### ■ Important Safety Reminder

CMBS is designed to reduce the severity of an unavoidable collision. It does not prevent collisions nor stop the vehicle automatically. It is still your responsibility to operate the brake pedal and steering wheel appropriately according to the driving conditions.

#### Blind Spot Information System\*<sup>1</sup>

Alerts you to a detected vehicle in your left or right blind spot while driving 20 mph (32 km/h) or higher.

When a vehicle is detected in your blind spot, the blind spot indicator turns on and stays lit until the area is clear.

When your turn signal is on and a vehicle is detected, the blind spot indicator blinks and a beep sounds until the area is clear or the turn signal is off.

#### ■ Changing Settings

Determine the warning type, or turn the system off.

1. From the Home screen, select Settings.
2. Select Vehicle. The vehicle must be in Park (P).
3. Select Driver Assist System Setup.
4. Select Blind Spot Info.
5. Select an alert type, or turn the system off.
6. Press Save.

■ **Important Safety Reminder**

Like all assistance systems, the Blind Spot Information System has limitations. Over-reliance on the system may result in a collision. The system is for your convenience only.

**⚠ WARNING**

Failure to visually confirm that it is safe to change lanes before doing so may result in a crash and serious injury or death. Do not rely only on the blind spot information system when changing lanes.

Always look in your mirrors, to either side of your vehicle, and behind you for other vehicles before changing lanes.

**LaneWatch™\*1**

Allows you to check the passenger side rear areas displayed on the audio/information screen when the turn signal is activated to the passenger's side.



■ **Activating LaneWatch**

Activate the right turn signal. The LaneWatch display appears. Check the display for blind spots, and visually confirm that it is safe to change lanes.

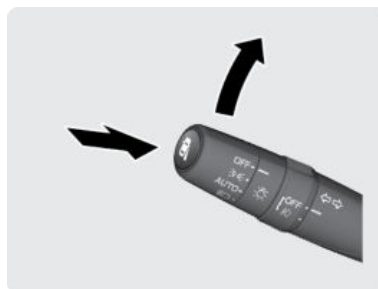

You can also press the LaneWatch button on the end of the turn signal switch to view a constant real-time display. Press it again to turn the display off.

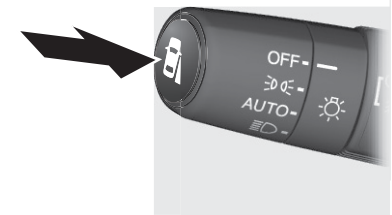

■ **Changing Settings**

Customize the display and how and when the display appears.

1. From the Home screen, select Settings.
2. Select Camera.
3. Select LaneWatch.
4. Select an option and make the preferred changes.
5. Press BACK to exit the menu.

■ **Important Safety Reminder**

Like all assistance systems, LaneWatch has limitations. Over-reliance on the system may result in a collision.

**Parking Sensor System\*1**

When the system senses an object when you are parking or backing up, indicators appear on the upper display and a series of beeps will sound. As you get closer to the object, the beep rate increases and the screen indicators change from blinking yellow to red.

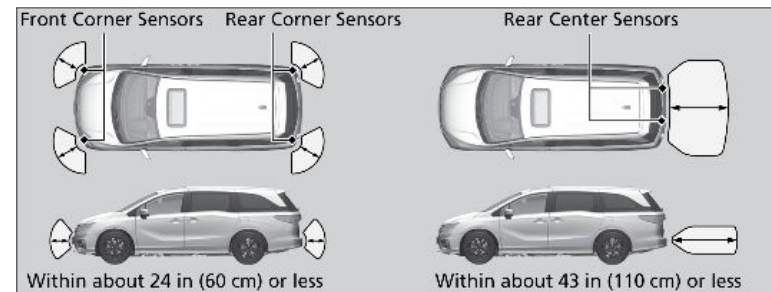

\*1 - If equipped,

\*1 - If equipped

■ Turning the System On or Off

Press the parking sensor button to turn the system on or off. A green indicator light appears on the button when the system is on.

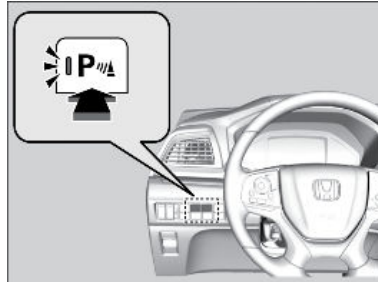

Cross Traffic Monitor\*1

Alerts you if a detected vehicle is approaching from a rear corner when your vehicle is in Reverse (R) at speeds of 3 mph (5 km/h) or lower.

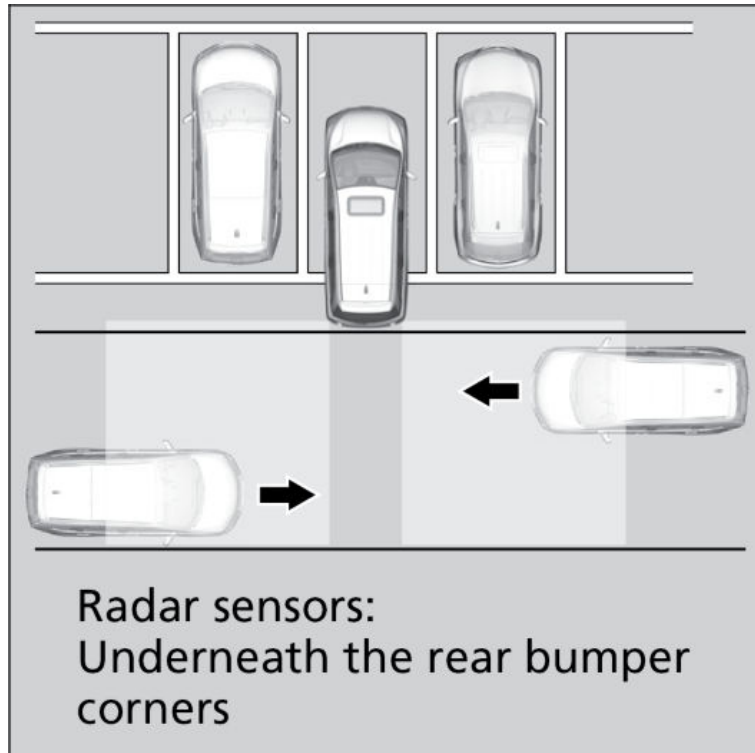

The system does not provide alerts for a vehicle that is moving away from your vehicle, and it may not detect pedestrians, bicycles, or stationary objects.

\*1 - If equipped

■ Turning the System On or Off

1. From the HOME screen, select Settings.
2. Select Camera.
3. Select Cross Traffic Monitor.
4. Select On or Off.

You can also select the status icon on the lower right corner of the screen when the monitor is on to turn it off.

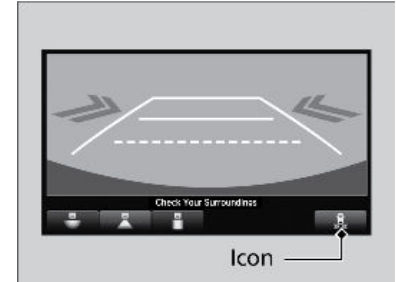

**CAUTION**

This system is for your convenience only. The system cannot detect all approaching vehicles or avoid all possible collisions. Failure to visually confirm that it is safe to reverse the vehicle before doing so may result in a collision. Do not rely only on the system's audible and visual alerts when reversing. Always look in your mirrors, to either side of your vehicle, and behind you for other vehicles before reversing your vehicle.

Multi-View Rear Camera

When you shift into Reverse (R), a real-time image of the area behind your vehicle is shown in the upper display, along with helpful parking guidelines.

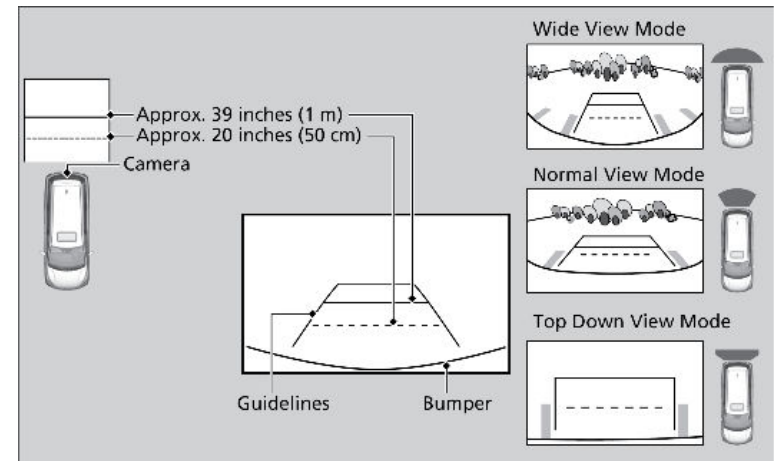

■ Changing Settings

Turn the guidelines on or off.

**Models with Color Audio**

1. Press the MENU/CLOCK button.
2. Select Settings.
3. Select Rear Camera.
4. Select Camera Guidelines.
5. Select On or Off.
6. Press the Back button to exit the menus.

**Models with Display Audio**

1. Press HOME.
2. Select Settings.
3. Select Camera.
4. Select Rear Camera.
5. Select Guidelines.
6. Select from the available choices. The active choice has a checkbox.
7. Select Save.

*The rear camera view is restricted. You cannot see the corner ends of the bumper or what is underneath the bumper. Its unique lens also makes objects appear closer or farther than they actually are.*

*Visually confirm that it is safe to drive before backing up. Certain conditions (such as weather, lightning, and high temperatures) may also restrict the rear view. Do not rely on the rearview display, which does not give you all the information about conditions at the rear of your vehicle.*

**Improving Fuel Economy and Reducing CO<sub>2</sub> Emissions**

Achieving fuel economy and reducing CO<sub>2</sub> emissions is dependent on several factors, including driving conditions, load weight, idling time, driving habits, and vehicle condition. Depending on these and other factors, you may not achieve the rated fuel economy of this vehicle.

**Refueling**

Use the proper fuel and refueling procedure to ensure the best performance and safety of your vehicle.

■ **Fuel Information**

**Use of unleaded gasoline of 87 octane or higher is recommended.**

- Honda recommends TOP TIER Detergent Gasoline where available.

- Do NOT use gasoline containing more than 15% ethanol.
- Do NOT use gasoline containing methanol.
- Do NOT use gasoline containing MMT.

**NOTICE**

We recommend quality gasoline containing detergent additives that help prevent fuel system and engine deposits. In addition, in order to maintain good performance, fuel economy, and emissions control, we strongly recommend the use of gasoline that does NOT contain harmful manganese-based fuel additives such as MMT, if such gasoline is available.

■ **How to Refuel**

Your fuel tank features a capless design. You can insert the filler nozzle directly into the filler pipe. The tank seals itself when you pull out the filler nozzle.

1. The fuel fill door is located at the left rear of the vehicle. Park next to the service pump that is most accessible.
2. Turn off the engine.
3. Press the area indicated by the arrow in the image to open the fuel fill door. The vehicle must be unlocked for the fuel fill door to open.
4. Insert the filler nozzle fully. When the tank is full, the nozzle clicks off automatically. Wait about 5 seconds before removing the filler nozzle.
5. Close the fuel fill door.

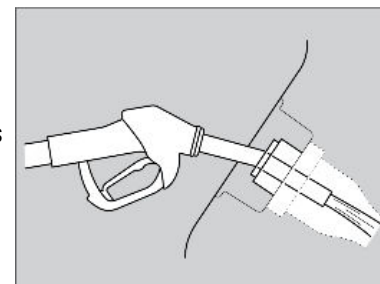
**⚠ WARNING**

Gasoline is highly flammable and explosive. You can be burned or seriously injured when handling fuel.

- Stop the engine, and keep heat, sparks, and flame away.
- Handle fuel only outdoors.
- Wipe up spills immediately.

## HANDLING THE UNEXPECTED

Learn about what to do in critical or emergency situations.

### Smart Entry System Battery Strength

If the battery life in your remote transmitter is weak, a message appears in the display with information on how to start the engine.

1. Touch the back of the remote transmitter to the ENGINE START/STOP button while the indicator is flashing.
2. With the brake pedal or clutch pedal pressed, press the ENGINE START/STOP button within 10 seconds.

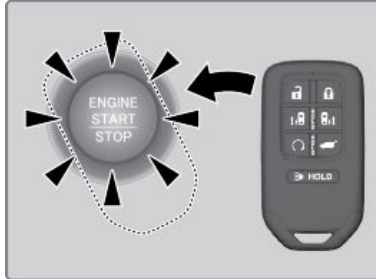

When you carry the remote transmitter (for example, in a pocket or purse) and it is outside the vehicle and within range (about 32 inches or 80 cm), you can lock or unlock the doors without handling the transmitter.

### Jump Starting

Turn off the power to electric devices, such as audio and lights. Turn off the engine, then open the hood.

1. Push the tabs to open the jump start box cover. Connect the first jumper cable to your vehicle's battery (+) terminal.
2. Connect the other end of the first jumper cable to the booster battery (+) terminal. Use a 12-volt booster battery only.
3. Connect the second jumper cable to the booster battery (-) terminal.

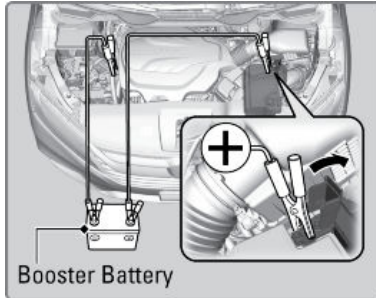

4. Connect the other end of the second jumper cable to the engine hanger as shown. Do not connect this jumper cable to any other part.
5. If your vehicle is connected to another vehicle, start the assisting vehicle's engine and increase its rpm slightly.
6. Attempt to start your vehicle's engine. If it turns over slowly, make sure that the jumper cables have good metal-to-metal contact.

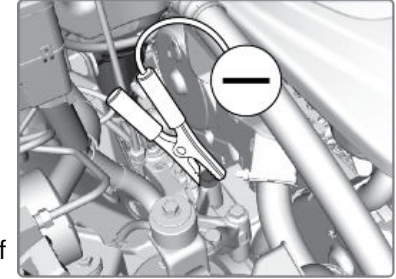

#### ⚠ WARNING

A battery can explode if you do not follow the correct procedure, seriously injuring anyone nearby.

Keep all sparks, open flames, and smoking materials away from the battery.

#### ⚠ WARNING

Battery posts, terminals, and related accessories contain lead and lead compounds. Wash your hands after handling.

### Overheating

#### Signs your engine is overheating:

- The temperature gauge needle is at the H mark
- The engine suddenly loses power
- Steam or spray comes out from under the hood
- The message Engine Temperature Too Hot appears on the display\*1.

#### First thing to do:

1. Immediately park the vehicle in a safe place. Turn off all accessories and turn on the hazard warning lights.
2. If no steam or spray is present: Keep the vehicle running and open the hood (See Under the Hood).

If steam or spray is present: Turn off the engine and wait until it subsides. Then, open the hood (See Under the Hood).

3. Check that the cooling fan is operating and stop the engine once the temperature gauge needle goes down. If the cooling fan is not operating, immediately stop the engine.

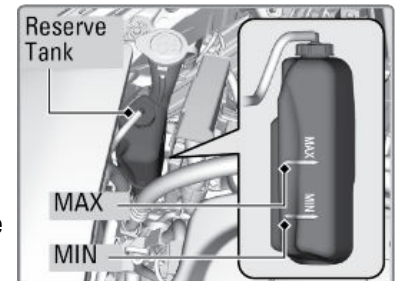

- Once the engine has cooled down, inspect the coolant level and check the cooling system components for leaks. If the coolant level in the reserve tank is low, add coolant until it reaches the MAX mark. If there is no coolant in the reserve tank, make sure the radiator is cool, then cover the radiator cap with a heavy cloth and open the cap. If necessary, add coolant up to the base of the filler neck, and put the cap back on.

Once the engine has cooled sufficiently, restart it and check the temperature gauge. If the temperature needle has gone down, resume driving. If it has not gone down, contact a dealer for repairs.

### ⚠ WARNING

Steam and spray from an overheated engine can seriously scald you.  
Do not open the hood if steam is coming out.

### ⚠ WARNING

Removing the radiator cap while the engine is hot can cause the coolant to spray out, seriously scalding you.  
Always let the engine and radiator cool down before removing the radiator cap.

### NOTICE

Continuing to drive with the temperature gauge needle at the H mark may damage the engine.

### Emergency Engine Stop

The ENGINE START/STOP button may be used to stop the engine due to an emergency situation even while driving. If you must stop the engine, choose one of the following operations:

- Press and hold the ENGINE START/STOP button for two seconds, **or**
- Firmly press the ENGINE START/STOP button three times.

The steering wheel will not lock. Because turning off the engine also disables the power assist the engine provides to the steering and braking systems, it will require significantly more physical effort and time to steer and slow the vehicle. Downshift gears and use both feet on the brake pedal, if necessary, to slow the vehicle and stop immediately in a safe place.

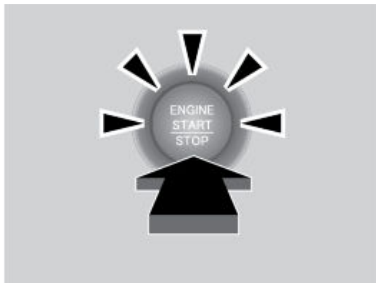

### NOTICE

Do not press the button while driving unless it is absolutely necessary for the engine to be switched off.

### Emergency Towing

Call a professional towing service if you need to tow your vehicle.

**Flat bed equipment:** The operator loads your vehicle on the back of a truck. **This is the only way to transport your vehicle.**

### NOTICE

Trying to lift or tow your vehicle by the bumpers will cause serious damage. The bumpers are not designed to support the vehicle's weight.

Improper towing such as towing behind a motorhome or other motor vehicle can damage the transmission.

### Tire Pressure Monitoring System (TPMS)

Monitors the tire pressure while you are driving.

If your vehicle's tire pressure becomes significantly low, the low tire pressure indicator comes on and a message appears.

#### ■ What to Do

Stop your vehicle in safe place. Check the tire pressure and adjust the pressure to the specified level. The specified tire pressure is on a label on the driver's doorjamb.

#### ■ Tire Pressure Monitoring System (TPMS) - Required Federal Explanation

##### U.S. models

Each tire, including the spare (if provided), should be checked monthly when cold and inflated to the inflation pressure recommended by the vehicle manufacturer on the vehicle placard or tire inflation pressure label. (If your vehicle has tires of a different size than the size indicated on the vehicle placard or tire inflation pressure label, you should determine the proper tire inflation pressure for those tires.)

As an added safety feature, your vehicle has been equipped with a tire pressure monitoring system (TPMS) that illuminates a low tire pressure telltale  when one or more of your tires is significantly under-inflated.

Accordingly, when the low tire pressure telltale illuminates, you should stop and check your tires as soon as possible, and inflate them to the proper pressure.

Driving on a significantly under-inflated tire causes the tire to overheat and can lead to tire failure. Under-inflation also reduces fuel efficiency and tire tread life, and may affect the vehicle's handling and stopping ability.

Please note that the TPMS is not a substitute for proper tire maintenance, and it is the driver's responsibility to maintain correct tire pressure, even if under-inflation has not reached the level to trigger illumination of the TPMS low tire pressure telltale.

Your vehicle has also been equipped with a TPMS malfunction indicator to indicate when the system is not operating properly. The TPMS malfunction indicator is combined with the low tire pressure telltale. When the system detects a malfunction, the telltale will flash for approximately one minute and then remain continuously illuminated. This sequence will continue upon subsequent vehicle start-ups as long as the malfunction exists.

When the malfunction indicator is illuminated, the system may not be able to detect or signal low tire pressure as intended.

TPMS malfunctions may occur for a variety of reasons, including the installation of replacement or alternate tires or wheels on the vehicle that prevent the TPMS from functioning properly.

Always check the TPMS malfunction telltale after replacing one or more tires or wheels on your vehicle to ensure that the replacement or alternate tires and wheels allow the TPMS to continue to function properly.

## Changing a Flat Tire

If a tire goes flat while driving, grasp the steering wheel firmly and brake gradually to reduce speed. Then stop in a safe place. Replace the flat tire with the compact spare tire. Go to a dealer as soon as possible to have the full-size tire repaired or replaced.

### Vehicles with a compact spare tire:

1. Park the vehicle on firm, level, non-slippery surface and set the parking brake.
2. Shift to Park (P).
3. Turn on the hazard warning lights and set the power mode to VEHICLE OFF.

### Getting Ready to Change the Tire

1. Remove the floor mat under the second row seat and pull up the carpet. Remove the floor lid.
2. Take the tool case out. Take the jack and wheel nut wrench out of the tool case.
3. Unscrew the wing bolt, then remove the spacer cone. Remove the spare tire.
4. Place the compact spare tire (wheel side up) under the vehicle body, near the tire that needs to be replaced.
5. Loosen each wheel nut about one turn using the wheel nut wrench.

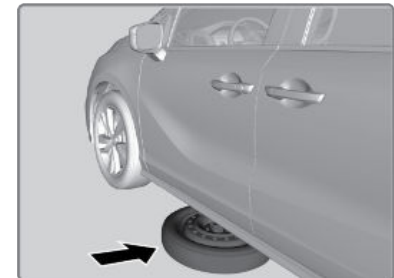
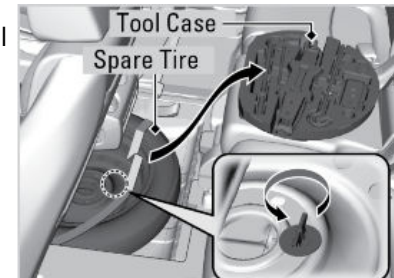
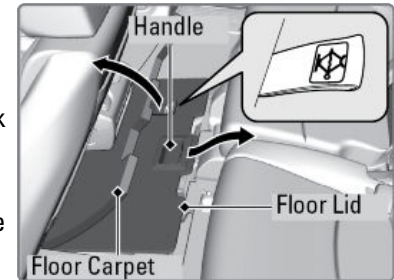

### ■ Setting Up the Jack

1. Place the jack under the jacking point closest to the tire to be changed.

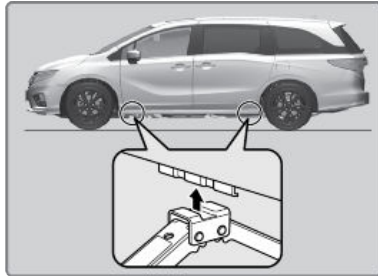

2. Turn the end bracket clockwise (as shown in the image) until the top of the jack contacts the jacking point. Make sure that the jacking point tab is resting in the jack notch.



3. Raise the vehicle, using the jack handle bar and the jack handle, until the tire is off the ground.

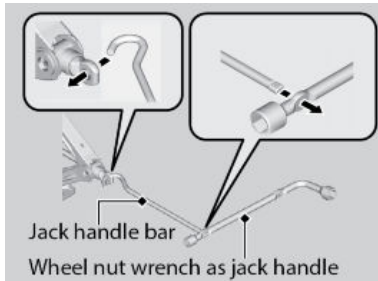

### ⚠ WARNING

The vehicle can easily roll off the jack, seriously injuring anyone underneath.

Follow the directions for changing a tire exactly, and never get under the vehicle when it is supported only by the jack.

### NOTICE

Do not use the jack if it doesn't work properly. Call your dealer or a professional towing service.

The following instructions must be followed to use the jack safely:

- Do not use the jack with people or luggage in the vehicle.
- Use the jack provided in your vehicle. Other jacks may not support the weight (load) or fit the jacking point.
- Do not use while the engine is running.

- Use only where the ground is firm and level.
- Use only at the jacking points.
- Do not get in the vehicle while using the jack.
- Do not put anything on top of or underneath the jack.

### ■ Replacing the Flat Tire

1. Remove the wheel nuts and flat tire.
2. Mount the compact spare tire. Replace the wheel nuts and lightly tighten them.
3. Lower the vehicle and remove the jack. Tighten the wheel nuts in the order indicated in the image. Go around, tightening the nuts, two to three times in this order. Do not overtighten the wheel nuts.



If you drive with the spare tire installed, the low tire pressure/TPMS indicator appears. The indicator stays on until a regular tire is installed and the TPMS system is recalibrated.

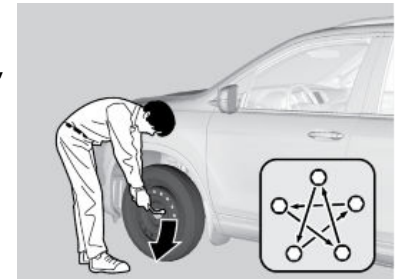

### ■ Storing the Flat Tire

1. Take out the storage bag from the tool case. Put the flat tire into the storage bag.

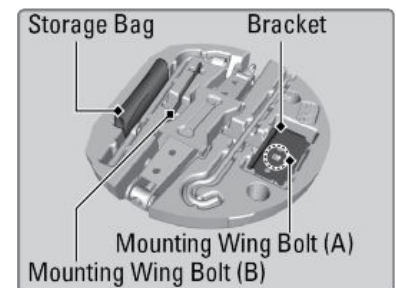



- On the driver's side of the third row seat, pull down the U-shaped carpet piece and use a coin to remove the plastic screw. Install the bracket and the mounting wing bolt (A) on the attachment point and tighten the bolt. Install the flat tire on the bracket with the inside of the wheel facing toward you.

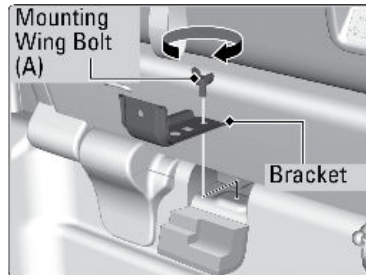
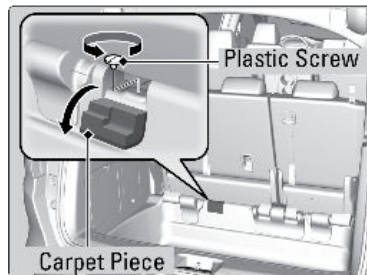

- Install the mounting wing bolt (B) to the bracket through one of the five wheel nut holes and tighten the bolt. As needed, poke a hole in the storage bag.

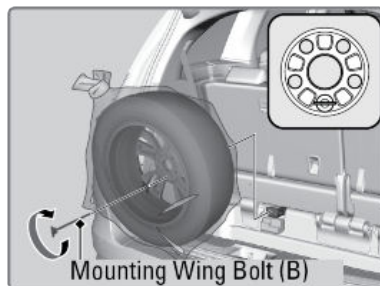

### Storing a flat tire on the folded third row seat

- Turn over the flap on the left side of the cargo area floor.
- Pull down the U-shaped carpet and remove the plastic screw with a coin.
- Place the flat tire face down on the attachment point.

- Put the tire mounting wing bolt (B) in the attachment point through one of the five wheel nut holes, and tighten the bolt. Poke a hole in the storage bag as needed.

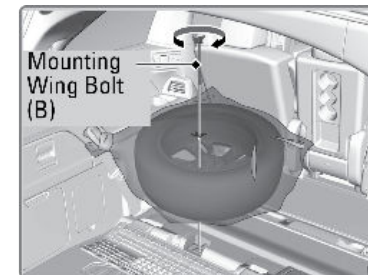
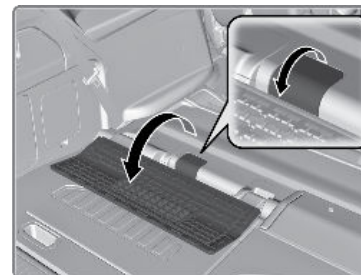

### ⚠ WARNING

Loose items can fly around the interior in a crash and can seriously injure the occupants.

Store the wheel, jack, and tools securely before driving.

### Fuse Locations

If any electrical devices are not working, turn the vehicle off and check to see if any applicable fuse is blown. Fuse locations are shown on the fuse box cover. Locate the fuse in question by the fuse number and box cover number. Refer to the Owner's Manual at [www.owners.honda.com](http://www.owners.honda.com) for a complete fuse chart.

#### ■ Engine Compartment Fuse Boxes

**Fuse Box A:** Located at the rear of the engine compartment, on the passenger side. Push the tabs to open the box.

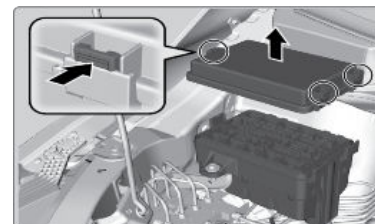

**Fuse Box B:** Located on the battery (+) terminal. Remove the engine compartment cover and the air intake duct (tools will be needed). Have a dealer replace these fuses.

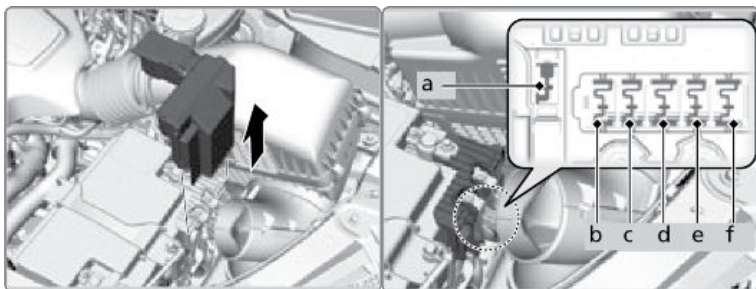

### ■ Interior Fuse Box

Located under the dashboard (behind the instrument panel). Fuse locations are shown on the label on the side panel (under the steering column). Locate the fuse in question by the fuse number and label number.

#### Fuse Box A

#### Fuse Box B

#### Fuse Box C\*<sup>1</sup>

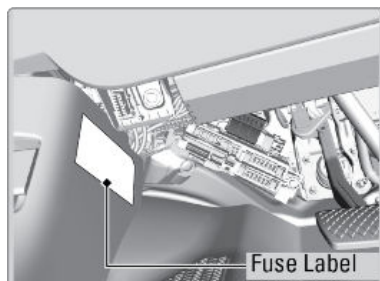
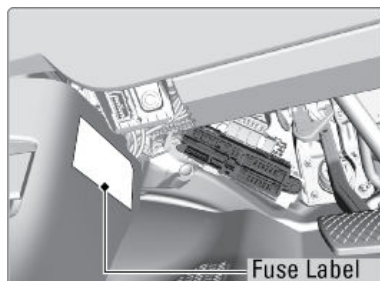
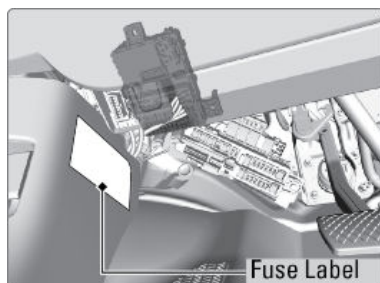

### Rear Side Interior Fuse Box

Located on the left side of the cargo area. Remove the cover to open.

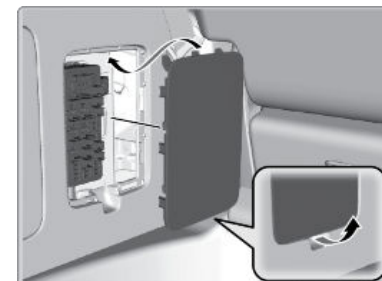

### ■ Inspecting and Changing Fuses

1. Turn off the vehicle, including all lights and accessories.
2. Remove the fuse box cover.
3. Check the fuses on the battery in the engine compartment.  
If the fuse is blown, have it replaced by a dealer.
4. Check the large fuse in the vehicle interior.  
If the fuse is blown, use a Phillips-head screwdriver to remove the screws and replace the fuse with a new one. Reinstall the screws.
5. Inspect the small fuses in the engine compartment and the vehicle interior.  
If there is a burned out fuse, remove it with the fuse puller and replace it with a new one.

### NOTICE

Replacing a fuse with one that has a higher rating greatly increases the chances of damaging the electrical system.

# MAINTENANCE

Learn about basic maintenance that you can perform on the vehicle yourself, as well as information about how to best maintain the vehicle.

## Safety Precautions

Some of the most important safety precautions are listed below however, we cannot warn you of every conceivable hazard that can arise in performing maintenance. Only you can decide whether or not you should perform a given task.

### ■ Maintenance Safety

- To reduce the possibility of fire or explosion, keep cigarettes, sparks, and flames away from the battery and all fuel-related parts.
- Never leave rags, towels, or other flammable objects under the hood. Heat from the engine and exhaust can ignite them, causing a fire.
- To clean parts, use a commercially available degreaser or parts cleaner, not gasoline.
- Wear eye protection and protective clothing when working with the battery or compressed air.
- Do not run the engine in confined spaces where carbon monoxide gas can accumulate.

### ■ Vehicle Safety

- The vehicle must be stationary and parked on level ground with the parking brake set and the engine off.
- Be aware that hot parts can burn you.
- Be aware that moving parts can injure you.

#### ⚠ WARNING

Improperly maintaining this vehicle or failing to correct a problem before driving can cause a crash in which you can be seriously hurt or killed. Always follow the inspection and maintenance recommendations according to the schedules in this guide.

#### ⚠ WARNING

Failure to properly follow maintenance instructions and precautions can cause you to be seriously hurt or killed. Always follow the procedures and precautions in this guide.

## Maintenance Minder™

When maintenance is due, the system message indicator comes on and a message appears on the display every time you turn the vehicle on. The messages notify you when to change the engine oil, or when to bring your vehicle to a dealer for indicated maintenance services.

Press the Homebutton on the steering wheel to change displays.



- Independent of the Maintenance Minder information, replace the brake fluid every 3 years.
- Independent of the Maintenance Minder information, adjust the valves during services A, B, 1, 2, or 3 if they are noisy.

U.S. models

**Maintenance, replacement, or repair of emissions control devices and systems may be done by any automotive repair establishment or individuals using parts that are certified to EPA standards.**

According to state and federal regulations, failure to perform maintenance on the maintenance main items marked with # will not void your emissions warranties. However, all maintenance services should be performed in accordance with the intervals indicated by the multi-information display.

### ■ Maintenance Minder Service Codes

These codes indicate what services are due on your vehicle.

U.S. Models

CODE	Maintenance Main Items
A	⊗ Replace engine oil*1
B	<ul style="list-style-type: none"> <li>⊗ Replace engine oil*1 and oil filter</li> <li>⊗ Inspect front and rear brakes</li> <li>⊗ Inspect tie rod ends, steering gearbox, and boots</li> <li>⊗ Inspect suspension components</li> <li>⊗ Inspect driveshaft boots</li> <li>⊗ Inspect brake hoses and lines (Including ABS/VSA ®)</li> <li>⊗ Inspect all fluid levels and condition of fluids</li> <li>⊗ Inspect exhaust system#</li> <li>⊗ Inspect fuel lines and connections#</li> </ul>

\*1: If the message Maintenance Due Now does not appear more than 12 months after the display is reset, change the engine oil every year.

# : See information on maintenance and emissions warranty in the first column on page 748.

\*2: If you drive in dusty conditions, replace the air cleaner element every 15,000 miles (24,000 km).

\*3: If you drive primarily in urban areas that have high concentrations of soot in the air from industry and from diesel-powered vehicles, replace the dust and pollen filter every 15,000 miles (24,000 km).

CODE	Maintenance Sub Items
1	⊗ Rotate tires
2	<ul style="list-style-type: none"> <li>⊗ Replace air cleaner element *2</li> <li>⊗ Replace dust and pollen filter *3</li> <li>⊗ Inspect drive belt</li> </ul>
3	⊗ Replace transmission fluid *4
4	<ul style="list-style-type: none"> <li>⊗ Replace spark plugs</li> <li>⊗ Replace timing belt and inspect water pump *5</li> <li>⊗ Inspect valve clearance</li> </ul>
5	⊗ Replace engine coolant
7	⊗ Replace brake fluid *6

\*4: **Except ELITE and TOURING grade models**

Driving in mountainous areas at very low vehicle speeds or trailer towing results in higher transmission temperatures. This requires transmission fluid changes more frequently than recommended by the Maintenance Minder. If you regularly drive your vehicle under these conditions, have the transmission fluid changed at 60,000 miles (100,000 km) or 3 years, thereafter every 30,000 miles (50,000 km) or 2 years.

\*5: If you drive regularly in very high temperatures (over 110°F, 43°C), in very low temperatures (under -20°F, -29°C), replace every 60,000 miles (100,000 km).

\*6: If a Maintenance Minder message does not appear more than 36 months after the display for item 7 is reset, change the brake fluid every 3 years.

Canadian Models

CODE	Maintenance Main Items
A	⊗ Replace engine oil*1
0	⊗ Replace engine oil*1 and oil filter

\*1: If the message Maintenance Due Now does not appear more than 12 months after the display is reset, change the engine oil every year.

\*2: If you drive in dusty conditions, replace the air cleaner element every 24,000 km (15,000 miles).

\*3: If you drive primarily in urban areas that have high concentrations of soot in the air from industry and from diesel-powered vehicles, replace the dust and pollen filter every 24,000 km (15,000 miles).

\*4: **Except TOURING grade model**

Driving in mountainous areas at very low vehicle speeds or trailer towing results in higher transmission temperatures. This requires transmission fluid changes more frequently than recommended by the Maintenance Minder. If you regularly drive your vehicle under these conditions, have the transmission fluid changed at 100,000 km (60,000 miles) or 3 years, thereafter every 50,000 km (30,000 miles) or 2 years.

\*5: If you drive regularly in very high temperatures (over 43°C, 110°F), in very low temperatures (under -29°C, -20°F), replace every 100,000 km (60,000 miles).

\*6: If a Maintenance Minder message does not appear more than 36 months after the display for item 7 is reset, change the brake fluid every 3 years.

# : See information on maintenance and emissions warranty in the first column on page 749.

CODE	Maintenance Sub Items
1	⊗ Rotate tires
2	<ul style="list-style-type: none"> <li>⊗ Replace air cleaner element *2</li> <li>⊗ Replace dust and pollen filter *3</li> <li>⊗ Inspect drive belt</li> </ul>
3	⊗ Replace transmission fluid *4
4	<ul style="list-style-type: none"> <li>⊗ Replace spark plugs</li> <li>⊗ Replace timing belt and inspect water pump *5</li> <li>⊗ Inspect valve clearance</li> </ul>
5	⊗ Replace engine coolant
7	⊗ Replace brake fluid *6
9	<ul style="list-style-type: none"> <li>⊗ Service front and rear brakes</li> <li>⊗ Inspect tie rod ends, steering gearbox, and boots</li> <li>⊗ Inspect suspension components</li> <li>⊗ Inspect driveshaft boots</li> <li>⊗ Inspect brake hoses and lines (including ABS/VSA ®)</li> <li>⊗ Inspect all fluid levels and condition of fluids</li> <li>⊗ Inspect exhaust system#</li> <li>⊗ Inspect fuel lines and connections#</li> </ul>

Under the Hood

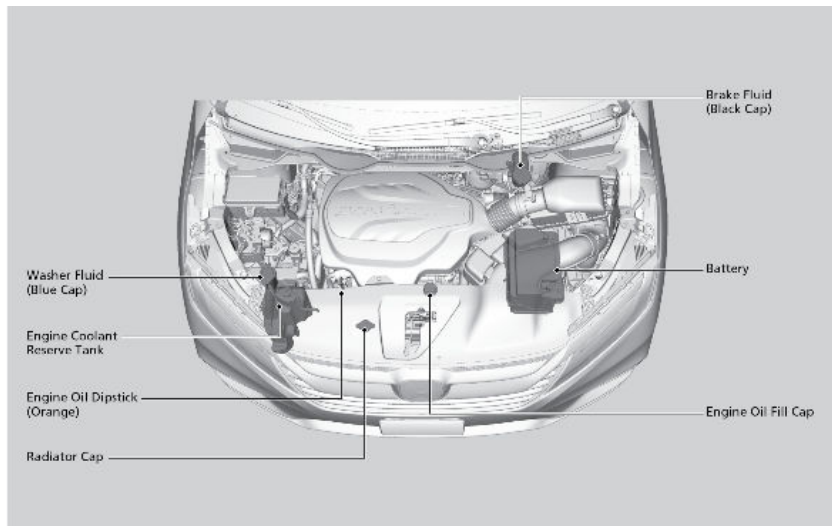

■ **Opening the Hood**

1. Park the vehicle on a level surface and set the parking brake.
2. Pull the hood release handle under the lower left corner of the dashboard.

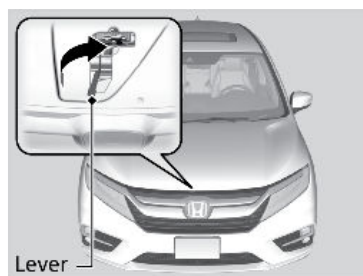
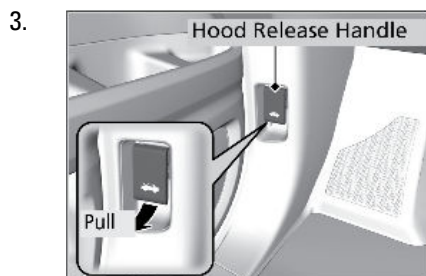

Push the hood latch lever in the center of the hood to release the lock mechanism, and open the hood.

4. Remove the support rod from the clamp using the grip. Mount the support rod in the hood.

When closing, remove the support rod, and stow it in the clamp, then gently lower the hood.

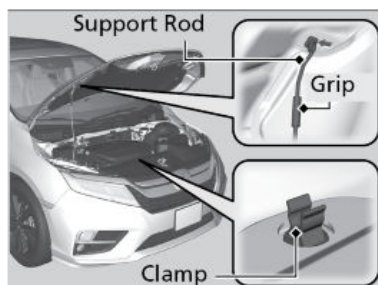

When closing the hood, lower it to approximately 12 inches (30 cm) and press firmly down with your hands.

**NOTICE**

Do not open the hood when the wiper arms are raised. The hood will strike the wipers, and may damage either the hood or the wipers.

**Engine Oil**

Park the vehicle on level ground. Wait approximately three minutes after turning the engine off before you check the oil.

■ **Checking the Oil**

1. Open the hood. (See Opening the Hood) Remove the dipstick (orange loop).
2. Wipe the dipstick with a clean cloth or paper towel.
3. Insert the dipstick all the way back into its hole.
4. Remove the dipstick again, and check the level. It should be between the upper and lower marks.

Add oil if necessary.

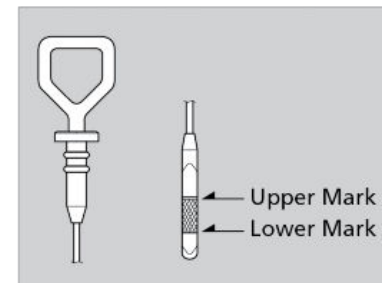

■ **Recommended Engine Oil**

- **Genuine Honda Motor Oil**
- **Premium-grade 0W-20 detergent oil with an API Certification Seal on the container**

This seal indicates the oil is energy conserving and that it meets the American Petroleum Institute's latest requirements. Use **Genuine Honda Motor Oil** or another commercial engine oil of suitable viscosity for the ambient temperature.

Use **Genuine Honda Motor Oil** or another commercial engine oil of suitable viscosity for the ambient temperature.

You may also use synthetic motor oil if it is labeled with the API Certification Seal and is of the specified viscosity grade.

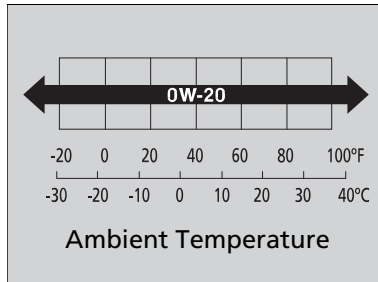

■ **Adding Oil**

1. Unscrew and remove the engine oil fill cap.
2. Add oil slowly.
3. Reinstall the engine oil fill cap and tighten it securely.
4. Wait for three minutes and recheck the engine oil dipstick.

**NOTICE**

Do not fill the engine oil above the upper mark. Overfilling the engine oil can result in leaks and engine damage.

■ **Resetting the Engine Oil Life**

If you change or replace the vehicle's engine oil yourself, you must reset the engine oil life.

**NOTICE**

Failure to reset the engine oil life after a maintenance service results in the system showing incorrect maintenance intervals, which can lead to serious mechanical problems.

**Engine Coolant**

Park the vehicle on level ground. Check the reserve tank and the coolant level in the radiator. **Use Honda Long Life Antifreeze/Coolant Type 2.**

■ **Checking the Reserve Tank**

1. Open the hood. (see Opening the Hood) Check the amount of coolant in the reserve tank.
2. If the coolant level is below the MIN mark, add the specified coolant until it reaches the MAX mark.
3. Inspect the cooling system for leaks.

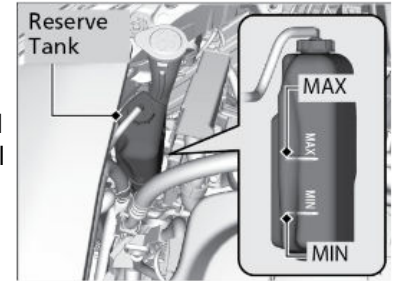

**NOTICE**

For vehicles used in temperatures below -31°F (-35°C), change the coolant from the standard 50:50 antifreeze:water mix to one with added antifreeze. Consult a dealer for more information.

■ **Adding Coolant**

1. Make sure the engine and radiator are cool.
2. Turn the radiator cap 1/8 turn counterclockwise and relieve any pressure in the coolant system.
3. Push down and turn the radiator cap counterclockwise to remove it.
4. The coolant level should be up to the base of the filler neck. Add coolant if it is low.
5. Put the radiator cap back on, and tighten it fully.

**WARNING**

Removing the radiator cap while the engine is hot can cause the coolant to spray out, seriously scalding you.

Always let the engine and radiator cool down before removing the radiator cap.

**NOTICE**

Pour the fluid slowly and carefully so you do not spill any. Clean up any spills immediately; they can damage components in the engine compartment.

### Checking the Battery

The battery condition is monitored by the sensor on the negative terminal. If there is a problem with the sensor, a warning message appears on the information display. Have your vehicle checked by a dealer.

#### ⚠ WARNING

The battery gives off explosive hydrogen gas during normal operation.

A spark or flame can cause the battery to explode with enough force to kill or seriously hurt you.

When conducting any battery maintenance, wear protective clothing and a face shield, or have a skilled technician do it.

**WARNING:** Battery posts, terminals, and related accessories contain lead and lead compounds. **Wash your hands after handling.**

### Window Washer Fluid

Check the amount of window washer fluid by looking at the reservoir. Fill if it is low. Pour the washer fluid carefully. Do not overflow the reservoir.

#### Canadian Models Only

If the washer fluid is low, a message appears on the Driver Information Interface

#### NOTICE

Do not use engine antifreeze or a vinegar/water solution in the windshield washer reservoir. Antifreeze can damage your vehicle's paint. A vinegar/water solution can damage the windshield washer pump.

### Brake Fluid

The fluid level should be between the MIN and MAX marks on the side of the tank. We recommend using **Honda Heavy Duty Brake Fluid DOT 3**.

Pour the fluid carefully.

If the fluid level is at or below the MIN mark, have a dealer inspect for leaks or worn brake pads as soon as possible.

#### NOTICE

Brake fluid marked DOT 5 is not compatible with your vehicle's braking system and can cause extensive damage.

### Changing Wiper Blades

If the wiper blades leave streaks across the windshield, try cleaning them first with a paper towel or soft cloth and wiper fluid. If the wiper blade rubber has deteriorated, you should change the wiper blades.

1. Set the power mode to VEHICLE OFF
2. While holding the wiper switch in the MIST position, set the power mode to ON, then to VEHICLE OFF. Both wiper arms are now set to the maintenance position.
3. Lift the driver side wiper arm first, then the passenger side.
4. Press and hold the tab, then slide the holder off the wiper arm.

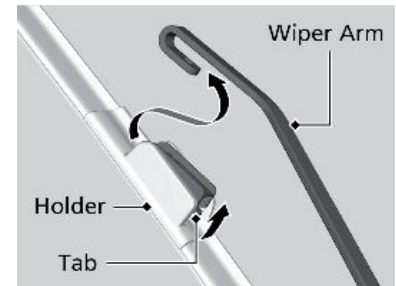
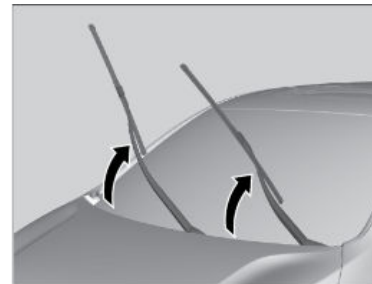

5. Pull the end of the wiper blade to the direction of the arrow until it unfastens from the end cap.
6. Pull the wiper blade to the opposite direction to slide it out from its holder.
7. Insert the flat side of the new wiper blade onto the bottom part of the holder. Insert the blade all the way.
8. Install the end of the wiper blade into the end cap.
9. Slide the wiper holder onto the wiper arm until it locks.
10. Lower the passenger side wiper arm first, then the driver side.
11. Set the power mode to ON and hold the wiper switch in the MIST positions until both wiper arms return to the standard position.

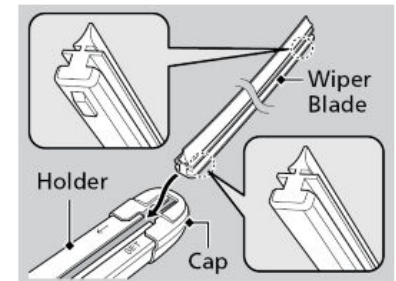
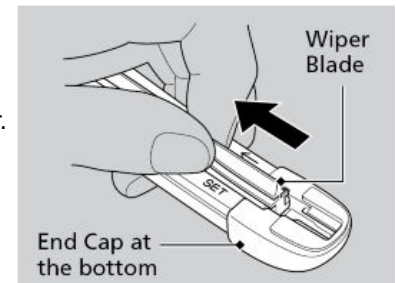

#### NOTICE

Avoid dropping the wiper arm, as it may damage the windshield.

### To Change the Rear Wiper Blade

1. Raise the wiper arm off.
2. Slide the wiper blade out from the end with the indent.
3. Remove the retainers from wiper blade and mount to a new rubber blade.
4. Slide the new wiper blade onto the holder. Make sure it is engaged correctly, then install the wiper blade assembly onto the wiper arm.

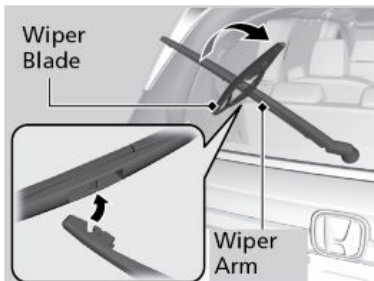

### NOTICE

Avoid dropping the wiper arm, as it may damage the windshield.

### Tire Information

To safely operate your vehicle, your tires must be of the proper type and size, in good condition with adequate tread, and properly inflated.

#### ■ Inflation Guidelines

- Properly inflated tires provide the best combination of handling, tread life, and comfort. Refer to the driver's doorjamb label or the specifications see SPECIFICATIONS for the specified pressure.
- Underinflated tires wear unevenly, adversely affect handling and fuel economy, and are more likely to fail from overheating.
- Overinflated tires make your vehicle ride harshly, are more prone to road hazards, and wear unevenly.
- Every day before you drive, look at each of the tires. If one looks lower than the others, check the pressure with a tire gauge.
- Measure the air pressure when tires are cold. This means the vehicle has been parked for at least 3 hours, or driven less than 1 mile (1.6 km). If necessary, add or release air until the specified pressure is reached. If checked when hot, tire pressure can be as much as 4-6 psi (30-40 kPa, 0.3-0.4 kgf/cm<sup>2</sup>) higher than checked when cold.
- At least once a month or before long trips, use a gauge to measure the pressure in all tires, including the spare\*<sup>1</sup>. Even tires in good condition can lose 1-2 psi (10-20 kPa, 0.1-0.2 kgf/cm<sup>2</sup>) per month.

\*1 - If equipped

#### ■ Inspection Guidelines

Every time you inflate the tires, check for the following:

- Any damage to tires, including bumps, bulges, cuts, splits, or cracks in the side or tread. Remove any foreign objects and inspect for air leaks. Replace tires if you see fabric or cord.
- Uneven or excessive tread wear. Have a dealer check the wheel alignment.
- Cracks or other damage around the valve stems.

#### ■ Wear Indicators

The groove where the wear indicator is located is 1/16 inch (1.6 mm) shallower than elsewhere on the tire. If the tread has worn so low that the indicator is exposed, replace the tire. Worn out tires have poor traction on wet roads.

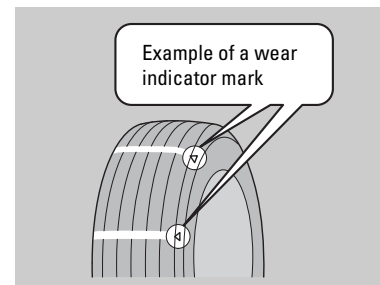

### ⚠ WARNING

Using tires that are excessively worn or improperly inflated can cause a crash in which you can be seriously hurt or killed. Follow all instructions in the owner's manual regarding tire inflation and maintenance.

#### ■ Tire and Loading Information Label

The label attached to the driver's doorjamb provides necessary tire and loading information.



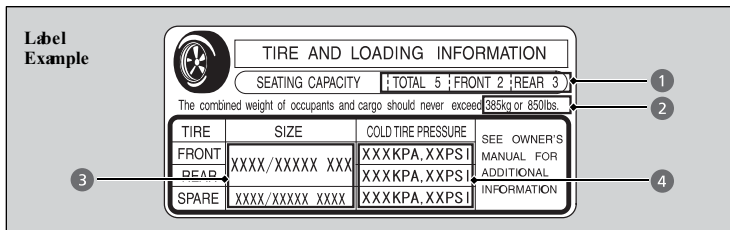

1. The number of people your vehicle can carry.
2. The total weight your vehicle can carry. Do not exceed this weight.
3. The original tire sizes for front, rear, and spare.
4. The proper cold tire pressure for front, rear, and spare.

**Tire and Wheel Replacement**

Replace your tires with radials of the same size, load range, speed rating, and maximum cold tire pressure rating (as shown on the tire’s sidewall). Using tires of a different size or construction can cause certain vehicle systems to work incorrectly. It is best to replace all four tires at the same time. If that isn’t possible, replace the front or rear tires in pairs.

If you change or replace a wheel, make sure that the wheel’s specifications match those of the original wheels. Only use TPMS-specified wheels approved for your vehicle.

**⚠ WARNING**

Installing improper tires on your vehicle can affect handling and stability. This can cause a crash in which you can be seriously hurt or killed. Always use the size and type of tires recommended in the Owner’s Manual.

**Tire Service Life**

The life of your tires is dependent on many factors, including driving habits, road conditions, vehicle loading, inflation pressure, maintenance history, speed, and environmental conditions (even when the tires are not in use).

In addition to regular inspections and inflation pressure maintenance, it is recommended that you have annual inspections performed once the tires reach five years old. All tires, including the spare, should be removed from service after 10 years from the date of manufacture, regardless of their condition or state of wear.

**Winter Tires**

If driving on snowy or frozen roads, mount all season tires marked “M+S”, snow tires, or tire chains; reduce speed and maintain sufficient distance between vehicles when driving. For winter tires, select the size and load ranges that are the same as the original tires, and mount them to all four wheels.

**Tire Chains**

Install tire chains on the front tires only. Because your vehicle has limited tire clearance, we strongly recommend using the following chains:

**Cable type: With 18-inch wheels: Peerless Autotrac 231905**

**Cable type: With 19-inch wheels: Peerless Autotrac 232405**

Mount chains as tightly as you can and make sure that they do not touch the brake lines or suspension.

**NOTICE**

Traction devices that are the wrong size or improperly installed can damage your vehicle’s brake lines, suspension, body, and wheels. Stop driving if they are hitting any part of the vehicle.

**⚠ WARNING**

Using the wrong chains, or not properly installing chains, can damage the brake lines and cause a crash in which you can be seriously injured or killed. Follow all instructions in this guide regarding the selection and use of tire chains.

**Tire Labeling**

The tires that came on your vehicle have a number of markings. Those you should be aware of are described below.

Here is an example of what each marking means:

**P235/60R18 102T**

- P: tire type (passenger vehicle)
- 235: tire width in millimeters
- 60: aspect ratio (tire section height as a percentage of its width)
- R: tire construction code (radial)
- 18: rim diameter in inches
- 102: load index (code indicating maximum load tire can carry)
- T: speed symbol (code indicating maximum speed rating)

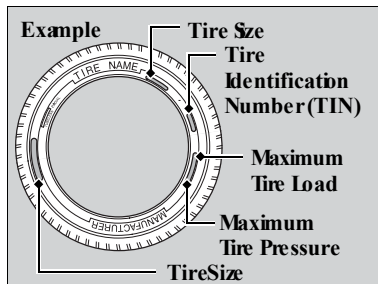

■ **Tire Identification Number (TIN)**

The tire identification number (TIN) is a group of numbers and letters that look like the following example. The TIN is located on the sidewall of the tire.

DOT B97R FW6X 2209

DOT: This indicates that the tire meets all requirements of the U.S. Department of Transportation.  
 B97R: Manufacturer's identification mark.  
 FW6X: Tire type code.  
 22 09: Date of manufacture.  
 Year Week

■ **Glossary of Tire Terminology**

**Cold Tire Pressure** – The tire air pressure when the vehicle has been parked for at least three hours or driven less than 1 mile (1.6 km).

**Load Rating** – The maximum load that a tire is rated to carry for a given inflation pressure.

**Maximum Inflation Pressure** – The maximum tire air pressure that the tire can hold.

**Maximum Load Rating** – The load rating for a tire at the maximum permissible inflation pressure for that tire.

**Recommended Inflation Pressure** – The cold tire inflation pressure recommended by the manufacturer.

**Treadwear Indicators (TWI)** – The projections within the principal grooves designed to give a visual indication of the degrees of wear of the tread.

**DOT Tire Quality Grading**

The tires on your vehicle meet all U.S. Federal Safety Requirements. All tires are also graded for treadwear, traction, and temperature performance according to Department of Transportation (DOT) standards. These gradings are explained below.

■ **Uniform Tire Quality Grading**

Quality grades can be found where applicable on the tire sidewall between tread shoulder and maximum section width.

For example:

**Treadwear 200**

**Traction AA**

**Temperature A**

All passenger car tires must conform to Federal Safety Requirements in addition to these grades.

■ **Treadwear**

The treadwear grade is a comparative rating based on the wear rate of the tire when tested under controlled conditions on a specified government test course. For example, a tire graded 150 would wear one and one-half (1 1/2) times as well on the government course as a tire graded 100. The relative performance of tires depends upon the actual conditions of their use, however, and may depart significantly from the norm due to variations in driving habits, service practices, and differences in road characteristics and climate.

■ **Traction**

The traction grades, from highest to lowest, are AA, A, B, and C. Those grades represent the tire's ability to stop on wet pavement as measured under controlled conditions on specified government test surfaces of asphalt and concrete. A tire marked C may have poor traction performance.

**WARNING:** The traction grade assigned to this tire is based on straight-ahead braking traction tests, and does not include acceleration, cornering, hydroplaning, or peak traction characteristics.

■ **Temperature**

The temperature grades are A (the highest), B, and C, representing the tire's resistance to the generation of heat and its ability to dissipate heat when tested under controlled conditions on a specified indoor laboratory test wheel. Sustained high temperature can cause the material of the tire to degenerate and reduce tire life, and excessive temperature can lead to sudden tire failure. The grade C corresponds to a level of performance which all passenger car tires must meet under the Federal Motor Vehicle Safety Standard No. 109. Grades B and A represent higher levels of performance on the laboratory test wheel than the minimum required by law.

**WARNING:** The temperature grade for this tire is established for a tire that is properly inflated and not overloaded. Excessive speed, underinflation, or excessive loading, either separately or in combination, can cause heat buildup and possible tire failure.

### Testing of Readiness Codes

Your vehicle has readiness codes as part of the onboard self-diagnostic system. Some states use these codes for testing to verify whether your vehicle's emissions components are working properly. The codes may not be read if you go through the testing just after the battery has gone dead or been disconnected.

To check if they are set, set the power mode to ON without starting the engine. The malfunction indicator lamp will come on for several seconds. If it goes off, the readiness codes are set. If it blinks five times, the readiness codes are not set.

If you are required to have your vehicle tested before the readiness codes are set, prepare the vehicle for retesting by doing the following:

1. Fill the gas tank to approximately 3/4 full.
2. Park the vehicle and leave the engine off for 6 hours or more.
3. Make sure the ambient temperature is between 40°F and 95°F (4°C and 35°C).
4. Turn the power system on.
5. Select a nearby, lightly traveled major highway where you can maintain a speed of 50 to 60 mph (80 to 97 km/h) for at least 20 minutes. Drive on the highway with the vehicle in Drive. Do not use cruise control.
6. Drive in city or suburban traffic for at least 10 minutes. When traffic conditions allow, let the vehicle coast for several seconds without using the accelerator pedal or the brake pedal.
7. Park the vehicle and leave the engine off for 40 minutes.

The readiness codes are erased when the battery is disconnected. The codes are set again only after several days of driving under a variety of conditions.

If a testing facility determines that the readiness codes are not set, you may be requested to return at a later date to complete the test or see your dealer.

## SPECIFICATIONS

### Vehicle

Model	Honda Odyssey
No. of Passengers:	
Front	2
Rear	2nd Row 3 (2 <sup>1</sup> ) 3rd Row 3
Total	8 (7 <sup>1</sup> )
<b>Weights:</b>	
Gross Vehicle Weight Rating	U.S.: 6,019 lbs (2,730 kg) Canada: 2,730 kg
Gross Axle Weight Rating (Front)	U.S.: 2,888 lbs (1,310kg) Canada: 1,310kg
Gross Axle Weight Rating (Rear)	U.S.: 3,230 lbs (1,465kg) Canada: 1,465kg
Gross Combined Weight Rating	U.S.: 8,565 lbs (3,885 kg) Canada: 3,885 kg

\*1: LX model

### Air Conditioning

Refrigerant Type	HFO-1234yf (R-1234yf)
Charge Quantity	20.3 - 22.0 oz (575 - 625 g)
Lubricant Type	RL85HM OIL (POE)
Quantity	7.3 - 8.2 cu-in (120 - 135 cm <sup>3</sup> )

### Engine and Fuel

<b>Engine Specifications</b>	
Displacement	212 cu-in (3,471 cm <sup>3</sup> )
Spark Plugs	NGK DILZKR7B11G

<b>Fuel</b>	
Fuel Type	Unleaded gasoline, Pump octane number of 87 or higher
Fuel Tank Capacity	19.5 US gal (73.8 L)

### Washer Fluid

Tank Capacity	U.S.: 2.6 US qt (2.5 L) Canada: 4.8 US qt (4.5 L)
---------------	--

### Brake Fluid

Specified	Honda Heavy Duty Brake Fluid DOT 3
-----------	------------------------------------

### Automatic Transmission Fluid

<b>ELITE and TOURING grade models</b>	
Specified	Honda Automatic Transmission Fluid ATF-Type 2
<b>Except ELITE and TOURING grade models</b>	
Specified	Honda Automatic Transmission Fluid ATF-Type 3.1 or higher

### Engine Oil

Recommended	Genuine Honda Motor Oil 0W-20 API Premium-grade 0W-20 detergent oil
Change	5.4 US qt (5.1 L)
Change including filter	5.7 US qt (5.4 L)
Capacity	

### Light Bulbs

Headlights (Low Beam)	55W (H11) <sup>*1, *2</sup> LED <sup>3</sup>
Headlights (High Beam)	60W (HB3) <sup>*1, *2</sup> LED <sup>3</sup>
Fog Lights	35W (H8) <sup>3</sup> LED <sup>3</sup>
Front Turn Signal/Parking Lights	28/8W <sup>1</sup>
Front Turn Signal Lights	28/8W <sup>*2, *3</sup>
Front Side Marker Lights	3CP
Parking/Daytime Running Lights	LED <sup>*2, *3</sup>
Daytime Running Lights	60W (HB3) <sup>1</sup>
Side Turn Signal Lights (on Door Mirrors)	LED <sup>*2, *3</sup>
Brake Lights	21W
Rear Side Marker/Tailights	LED
Rear Turn Signal Lights	21W
Back-Up Lights	21W
Tailights	LED
High-Mount Brake Light	LED
Rear License Plate Light	LED
Map Lights (Front)	5W
Map Lights (Rear)	5W
Cargo Area Light	8W
Vanity Mirror Lights	1.4W
Door Courtesy Lights	3.8W (2CP)
Glove Box Light	1.4W
Foot Lights	LED <sup>*1</sup>
Console Compartment Light	1.4W <sup>*4</sup>
Door Inner Handle Lights	LED <sup>*5</sup>
Instrument Panel Ambient Lights	LED <sup>*5</sup>
Pass Through Light	LED <sup>*5</sup>

\*1: LX and LX-LS models

\*2: EX, EXL, EXL-NR, EX-R, EXLNAV, and EXLRES models

\*3: Elite and TRG models

\*4: EX-R, EXL-NR, EXLNAV, EXLRES, TRG, and ELITE models

\*5: Elite and Canadian TRG models

### Engine Coolant

Specified	Honda Long-Life Antifreeze/Coolant Type2
Ratio	50/50 with distilled water
Capacity	1.69 US gal (6.38 L) <sup>*1</sup>
	1.68US gal (6.37 L) <sup>*2</sup>
	(change including the remaining 0.19 US gal (0.73 L) in the reserve tank)

\*1: ELITE and TOURING models

\*2: Except ELITE and TOURING models

### Tire

Regular	Size	235/60R18 103H 235/55R19 101H <sup>*1</sup>
	Pressure psi(kPa(kgf/cm <sup>2</sup> ))	35 (240 (2.4)) 36 (250 (2.5)) <sup>*1</sup>
Compact Spare	Size	T135/80D17 103M
	Pressure psi(kPa(kgf/cm <sup>2</sup> ))	60 (420 (4.2))
Wheel Size	Regular	18 x 7 1/2J 19 x 7 1/2J <sup>*1</sup>
	Compact Spare	17 x 4T

\*1: U.S. Elite and Canadian TRG models

## CUSTOMER INFORMATION

Learn about information specific to you as a Honda customer and how to get help.

### Frequently Asked Questions/Troubleshooting

Below are some frequently asked questions and troubleshooting items that you may have about the vehicle.

**Q:** How do I set the vehicle clock?

**A:** For vehicles without navigation, see Setting the Clock. For vehicles with navigation, the time is automatically set using GPS signals.

**Q:** Why doesn't the vehicle start when I press the ENGINE START/STOP button?

**A:** The brake pedal must be pressed to start the vehicle.

**Q:** What is the AUTO setting on my headlight lever?

**A:** When in the AUTO position, the vehicle's exterior lights will automatically turn on or off depending on the ambient lighting.

**Q:** Why won't the driver's door unlock when I grab the door handle, even though the keyless access remote\*1 is within range?

**A:** If you pull the handle too quickly, the system may not have time to confirm the door is unlocked. Wait to hear a beep to confirm the door is unlocked. If you are wearing gloves, the system may be slow to respond.

**Q:** After my battery was disconnected or went dead, the audio system is asking for a code. Where do I find this?

**A:** In most cases, you do not need to enter a code. Turn on the vehicle, then press and hold the audio power button until the system reactivates.

**Q:** Is my phone compatible with *Bluetooth® features? How do I pair my phone?*

**A:** To check phone compatibility, visit *handsfreelink.com* (US) or *handsfreelink.ca* (Canada). For pairing instructions, see Pairing a Phone.

**Q:** Every time I press the Talk button, the system gives me voice prompts \*1. Can I turn these off?

**A:** You can press the Talk button a second time to interrupt the guidance. Or, you can turn guidance on or off permanently via System settings. See Voice Portal Commands.

**Q:** The amber indicator with a tire and an exclamation mark is on. What do I do?

**A:** Either your tire pressure is low or you recently filled a tire. See Tire Pressure Monitoring System (TPMS).

### Contact Us

Honda dealer personnel are trained professionals. They should be able to answer all your questions. If you encounter a problem that your dealership does not solve to your satisfaction, please discuss it with the dealership's Service Manager or General Manager. If you are dissatisfied with the decision made by the dealership's management, contact Honda Automobile Customer Service.

#### U.S. owners

American Honda Motor Co., Inc. Tel: (800) 999-1009  
 Honda Automobile Customer Service Fax: (310) 783-3023  
 Mail Stop 100-5E-8A Twitter:@HondaCustSvc  
 Torrance, CA 90501-2746

#### Canadian owners

Honda Canada, Inc. Tel: (888) 946-6329  
 Customer Relations Fax: (877) 939-0909  
 180 Honda Blvd. E-mail: honda\_cr@ch.honda.com  
 Markham, ON L6C 0H9

#### In Puerto Rico and the U.S. Virgin Islands

Bella International  
 P.O. Box 190816  
 San Juan, PR 00919-0816  
 Tel: (787) 620-7546

When you call or write, please provide the following information:

- Vehicle Identification Number
- Date of purchase
- Odometer reading of your vehicle
- Your name, address, and telephone number
- A detailed description of the problem
- Name of the dealer who sold the vehicle to you

### Honda Roadside Assistance

24-hour emergency road service is available to you in the United States and Canada throughout your 3 year/36,000 mile warranty term. Services include jump starting, flat tire and lockout assistance, towing, and more (limitations apply). Call (866) 864-5211 (U.S.) or (800) 465-7587 (Canada).

\*1 - If equipped

## Warranty Coverages

Below is a brief summary of the warranties covering your new vehicle.

**New Vehicle Limited Warranty:** Covers your new vehicle, except for the emissions control system and accessories, against defects in materials and workmanship.

**Emissions Control Systems Defects Warranty and Emissions Performance Warranty:** Covers your vehicle's emissions control systems. Time, mileage, and coverage are conditional.

**Seat Belt Limited Warranty:** Covers seat belts that fail to function properly.

**Rust Perforation Limited Warranty:** Covers all exterior body panels that rust through from the inside.

**Accessory Limited Warranty:** Covers Honda accessories.

**Replacement Parts Limited Warranty:** Covers all a Honda replacement parts against defects in materials and workmanship.

**Replacement Battery Limited Warranty:** Provides prorated coverage for a replacement battery purchased from a Honda dealer.

**Replacement Muffler Lifetime Limited Warranty:** Covers a replacement muffler for the duration of the ownership.

Restrictions and exclusions apply to all these warranties. See the Warranty Information booklet or visit [owners.honda.com](http://owners.honda.com) (U.S.) or [www.myhonda.ca](http://www.myhonda.ca) (Canada) for complete descriptions of each warranty, including time, mileage, and other conditional limitations.

Your vehicle's original tires are covered by their manufacturer. Tire warranty information can be found at [owners.honda.com](http://owners.honda.com) (U.S.) or [www.myhonda.ca](http://www.myhonda.ca) (Canada).

## EPA Contact Information

An owner may obtain further information concerning emission warranties or report violations of the term of the emission warranties by contacting:

U.S. Environmental Protection Agency  
Office of Transportation and Air Quality  
Compliance Division, Light-Duty Vehicles Group  
Attn: Warranty Complaints  
2000 Traverwood Drive  
Ann Arbor, MI 48105  
Email: [complianceinfo@epa.gov](mailto:complianceinfo@epa.gov)

## VOICE COMMAND INDEX

Learn about the available voice commands to help you operate the vehicle. The system recognizes only those commands shown here. Press the TALK button before you say a command.

### Voice Portal Commands

When you press the TALK button, the Voice Portal screen appears. Say one of the options, and follow the system prompts.

- Phone
- Audio
- Navigation\*<sup>2</sup>

### Phone Commands

The system accepts these commands on most screens.

- Call (name)
- Call (phone number)
- Call (category)

### Audio Commands\*<sup>1</sup>

The system accepts these commands on the dedicated screen for the voice recognition of the audio.

- Tune to <87.7-107.9> FM
- Tune to <530-1710> AM
- SiriusXM\*<sup>1</sup> channel (1-999)
- SiriusXM\*<sup>1</sup> channel (station name)
- USB play album
- USB play genre
- USB play playlist
- USB play music
- USB play artist
- USB play song

### Navigation Commands\*<sup>2</sup>

When you press the Talk button and say "Navigation," you can say one of the options below. Follow the system prompts.

- Show/View map
- Go home
- Find address
- Stop route
- Detour
- Find city
- Recent Places
- Find intersection

\*<sup>2</sup> - Models with navigation only  
\*<sup>1</sup> - If equipped

## INDEX

Airbags.....7, 8, 10, 11, 13	Clock.....55
Advanced Airbags.....7	Contact Us.....145
Airbag Care.....13	Cruise Control.....97, 99
Airbag System Components.....11	Adaptive Cruise Control (ACC).....99
Airbag System Indicators.....10	Customized Features.....54
Front Airbags.....7	Doors.....30, 31
Side Airbags.....8	Front Door Inner Handle.....31
Side Curtain Airbags.....8	Lock Tab.....30
Audio and Connectivity.....56–72	Master Door Lock Switch.....31
Adjusting the Sound.....57	Engine.....91, 116
Android Auto.....62	Emergency Engine Stop.....116
Apple CarPlay.....60	ENGINE START/STOP Button.....91
Bluetooth Audio.....69	Floor Mats.....49
FM/AM Radio.....65	Frequently Asked Questions/ Troubleshooting.....144
iPod.....66	Fuel.....112
SiriusXM Radio.....66	Fuel Information.....112
USB Flash Drive.....68	Refueling.....112
USB Port.....56	Fuses.....123, 125
Bluetooth Handsfreelink (HFL).....73–79	Changing.....125
Dialing a Number.....76	Location.....123
Making a Call.....76	Gear Selection.....91
Pairing a Phone.....74	Shifting.....91
Using Speed Dial.....78	Headlights.....38, 39
Using the Phonebook.....77	Auto High Beam System.....39
Braking.....94, 95, 105	HomeLink Universal Transceiver.....51
Anti-Lock Brake System (ABS).....95	HondaLink.....59, 60
Brake Assist System.....95	HondaLink Assist.....60
CMBS.....105	Immobilizer.....24
Foot Brake.....94	Instrument Panel Indicators.....23–27
Parking Brake.....94	Jump Starting.....114
Brightness Control.....37	Lane Keeping Assist System (LKAS).....102
Carbon Monoxide Gas.....4	LaneWatch.....108
Child Safety.....13, 16, 18, 19, 31	Lights.....37
Child Seat with lap/shoulder belt...18	Interior Lights.....37
Child seat with Tether.....19	Maintenance.....126–142
Childproof Door Locks.....31	Battery.....134
LATCH-Compatible Child Seat.....16	Brake Fluid.....134
Selecting a Child Seat.....16	Engine Oil.....131
Climate Control System.....52, 53	
Heated Seats.....53	

Maintenance Minder.....127	Rear Seats.....45
Opening the Hood.....130	Smart Entry System.....29, 114
Under the Hood.....129	Specifications.....143
Window Washer Fluid.....134	Light Bulbs.....143
Wiper Blades.....135	Steering Wheel Adjusting.....49
Mirrors.....49–51	Tires.....117, 118, 121, 136–140
Door Mirrors.....50	Flat Tire.....118
Rearview Mirror.....50	Replacing Flat Tire.....121
Reverse Tilt Down Mirrors.....51	Tire and Loading Information Label.....137
Moonroof.....36	Tire and Wheel Replacement.....138
Multi-View Rear Camera.....111	Tire Chains.....139
Navigation.....80–84	Tire Identification Number (TIN)...140
Home Address.....81	Tire Information.....136
Map Legend.....84	Tire Labeling.....139
Place Category.....82	Tire Pressure Monitoring System (TPMS).....117
Recent Places.....83	Tire Quality Grading.....140
Routing.....84	Tire Service Life.....138
Saved Places.....83	Tire Terminology.....140
Steering Wheel Controls.....80	Wear Indicators.....137
Street Address.....82	Winter Tires.....139
Overheating.....115	Towing.....88, 117
Parking Sensor System.....109	Emergency Towing.....117
Power Outlets 12-Volt.....57	Load Limits.....88
Readiness Codes.....142	Trailer Weight.....88
Road Departure Mitigation (RDM)..104	Towing a Trailer.....88
Safety.....3–22	Turn Signals.....39
Reporting Safety Defects.....22	Vehicle Stability Assist System (VSA).....96
Safety Label Locations.....21	Voice Command Index.....147
Seat Belts.....4–7	Walk Away Auto Lock.....29
Fastening a Seat Belt.....6	Warranty.....146
Inspection.....5	Warranty Coverages.....146
Lap/Shoulder Belts.....4	Window.....35
Proper Use.....5	Power Windows.....35
Shoulder Anchor.....7	Wipers.....41
Seating.....42–45	Intermittent Wipers.....41
Driver Seat.....42	
Driving Position Memory System...43	
Head Restraints.....44	

# DISCLOSURES

## California Proposition 65 Warning

**⚠️WARNING:** Operating, servicing and maintaining a passenger vehicle or off-highway motor vehicle can expose you to chemicals including engine exhaust, carbon monoxide, phthalates, and lead, which are known to the State of California to cause cancer and birth defects or other reproductive harm. To minimize exposure, avoid breathing exhaust, do not idle the engine except as necessary, service your vehicle in a well-ventilated area and wear gloves or wash your hands frequently when servicing your vehicle. For more information go to [www.p65Warnings.ca.gov/passenger-vehicle](http://www.p65Warnings.ca.gov/passenger-vehicle).

## California Perchlorate Contamination Prevention Act

The airbags, seat belt tensioners, and CR-type batteries in this vehicle may contain perchlorate materials-special handling may apply. See [www.dtsc.ca.gov/hazardouswaste/perchlorate/](http://www.dtsc.ca.gov/hazardouswaste/perchlorate/) for more information.

## End User License Agreement

Your vehicle comes equipped with software, which is governed by the End User License Agreement in this vehicle's Owner's Manual, and which contains a binding arbitration clause. Please refer to the End User License Agreement for the terms and conditions governing your use of the installed software, as well as the applications, services, functions, and content provided through the software. Your use of the installed software will serve as your consent to the terms and conditions of the End User License Agreement.

You may opt out of the arbitration provisions within 30 days of your initial use of the Software by sending a signed, written notice to HONDA at American Honda Motor Co., Inc. Honda Automobile Customer Services Mail Stop 100-5E-8A , 1919 Torrance Blvd. Torrance, CA 90501-2746.